

US5 Connector

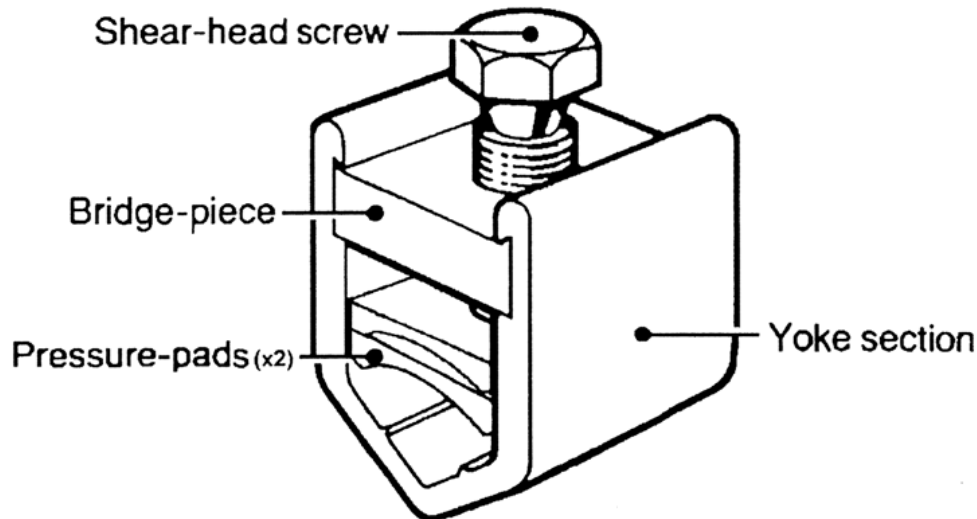

Principle Application

Stranded service connections from stranded sector shaped mains conductor.

Connector Reference	Core c.s.a. (mm ²)			
	Mains		Service	
	min.	max.	min.	max.
US5	185	300	35	70

The Hepworth US connector has been designed to connect stranded circular copper services to either three or four core sector shaped stranded aluminium mains conductors.

Ease of fitting and simplicity of use were fundamental objectives adopted in the design of this range of connectors, with the Hepworth shear head screw principle ensuring that a reliable and consistent connection is achieved without the need for specialised tooling.

Secondary Application

Stranded service connections from stranded circular mains conductors.

Connector Reference	Core c.s.a. (mm ²)			
	Mains		Service	
	min.	max.	min.	max.
US5	120	185	35	70

US5 Connector

Physical Dimensions

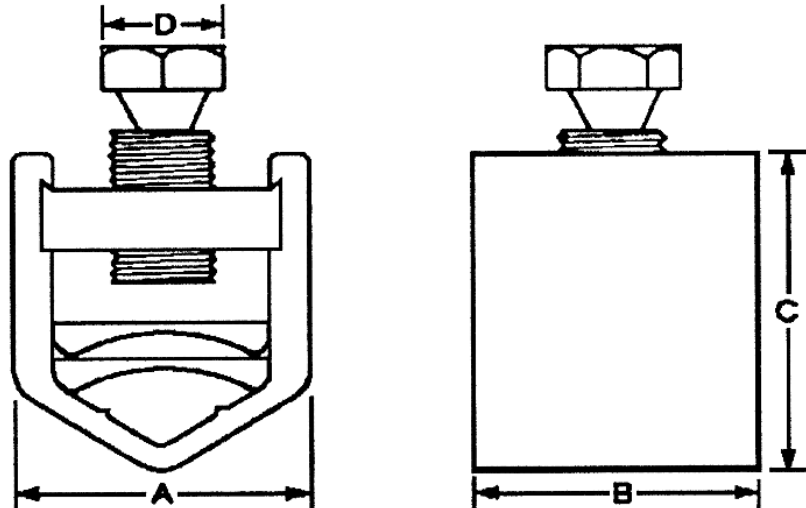

Ref Code	DIMENSIONS (mm)			
	A	B	C	D
US5	42	40	53	17

Material

Aluminium Alloy.

Fitting Instructions

Separate the main cable cores sufficiently to allow the yoke section to be fitted around the conductor and strip the insulation from the core equal to the connector length plus 5mm. Cut the service conductor to length, strip the insulation to suit, then separate the individual strands and splay out to form a single layer that will spread out over the back radius of the mains conductor.

Loosely assemble the connector around the cores by inserting the bridge piece and locating the pressure pad over the splayed out service strands, then tightening the shear head screw until positive location is achieved. Check for even distribution of the service strands then finally tighten the screw until the head shears.

If copper conductors are to be jointed they should be wrapped in brass gauze. In case of a copper service conductor being jointed onto a stranded aluminium main, care must be taken to ensure that the individual strands of the service conductor are spread out in the fashion described above within the wrap of the brass gauze. All conductors must be thoroughly abraded.