

**WM1, WM2 & WM3 Connectors**

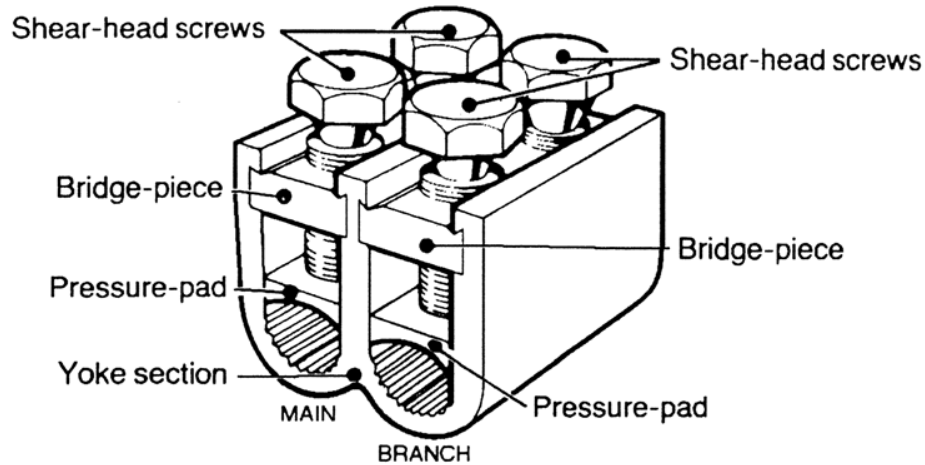

**Principle Application**

Stranded sector shaped conductors in the following ranges: -

**Range**

Connector reference	Core c.s.a. (mm <sup>2</sup> )				Approx Unit Wt. (gms)
	Mains		Branch		
	min.	max.	min.	max.	
WM1	16*	95	16*	95	120
WM2	50	185	50	185	200
WM3	120	300	120	300	315

The Hepworth WM range of mains branch connectors has been designed to accommodate three or four core sector shaped stranded conductors in the ranges specified above.

The connector employs the proven shear-head screw principle to ensure that a consistent and reliable connection is achieved. Fitting is completed by the use of orthodox hand tools only, and no specialised equipment or techniques are required.

Each connector is supplied in a sealed pack together with fitting instructions, details of which are included in the technical data overleaf.

**Secondary Application**

These connectors can accept stranded circular conductors to BS 6360 (copper) and BS 6791 (aluminium) in the main and/or branch sides of the connector in the following ranges: -

Reference Code	Core c.s.a. (mm <sup>2</sup> )			
	Mains		Branch	
	min.	max.	min.	max.
WM1	16	70	16	70
WM2	50	150	50	150
WM3	120	240	120	240

**WM1, WM2 & WM3 Connectors**

**Physical Dimensions**

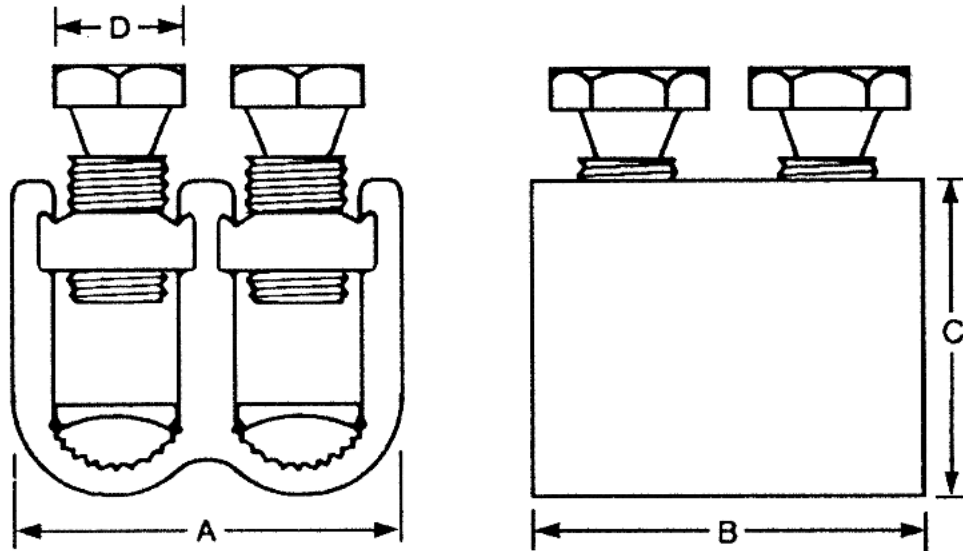

Ref. Code	Dimensions (mm)			
	A	B	C	D
WM	41	40	34	13
WM2	50	50	41	17
WM3	59	60	49	17

**Material**

Aluminium Alloy.

**Fitting Instructions**

Separate the main cable cores sufficiently to allow the yoke section to be fitted around the conductor and strip the insulation from the core equal to the connector length plus 5 mm. Thoroughly abrade the exposed conductor and loosely assemble one side of the connector around the core by fitting the bridge piece, inserting the pressure pad and tightening the main screws until the connector is positively located. Set and locate the branch core, then cut to length, strip insulation to suit and thoroughly abrade the exposed conductor before assembling into the connector as described above. Complete the operation by tightening down the mains screws consecutively, one turn at a time, until both heads shear, then repeating the operation for the branch screws.

It is suggested that conductors below the minimum range requirements of 16 mm<sup>2</sup> are doubled and, if needed, redoubled to achieve the required cross-sectional area and, if copper conductors are to be jointed, they should be wrapped in brass gauze in order to improve the electrical stability of the interface connection.