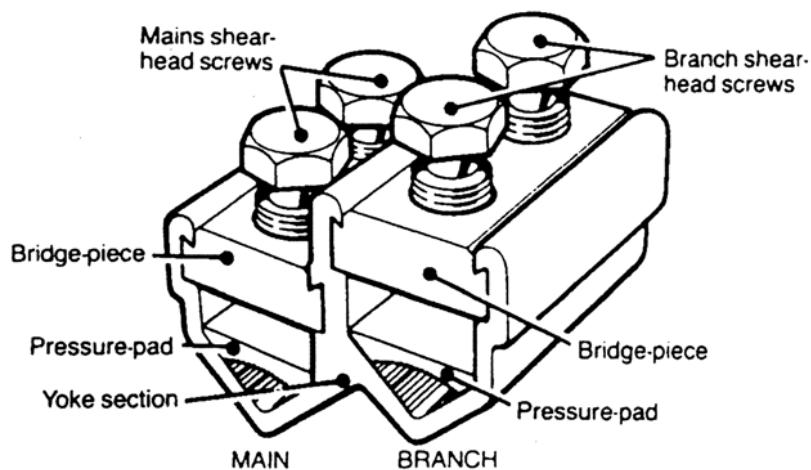

**WB1, WB2 & WB3 Connectors**

Registered Design No: 993197

**Principal Application**

Stranded sector shaped conductors.

**Range**

Connector reference	Core c.s.a. (mm <sup>2</sup> )				Approx Unit Wt. (gms)
	Mains		Branch		
	min.	max.	min.	max.	
WB1	150	300	150	300	425
WB2	300	500*	300	500*	505
WB3	300	500	150	300	490

\* Sector core dimensions to BS 6791 only

The Hepworth WB range of mains branch connectors has been designed to accommodate three or four core sector shaped stranded conductors in the ranges specified above.

Ease of fitting and simplicity of use were fundamental objectives adopted in the design of these connectors, and the Hepworth shear head screw principle ensures that a reliable and consistent connection is achieved without the need for specialised tooling.

Each connector is supplied in a sealed pack together with fitting instructions, details of which are included in the technical data overleaf.

**WB1, WB2 & WB3 Connectors****Secondary Applications**

These connectors can accept stranded circular conductors to BS6360 (copper) and BS6791 (aluminium) in the main and/or branch sides of the connector.

**Range**

Ref. Code	Core c.s.a. (mm <sup>2</sup> )			
	Main		Branch	
	Min.	Max.	Min.	Max.
WB1	95	240	120	300
WB2	185	300	240	400
WB3	185	300	120	300

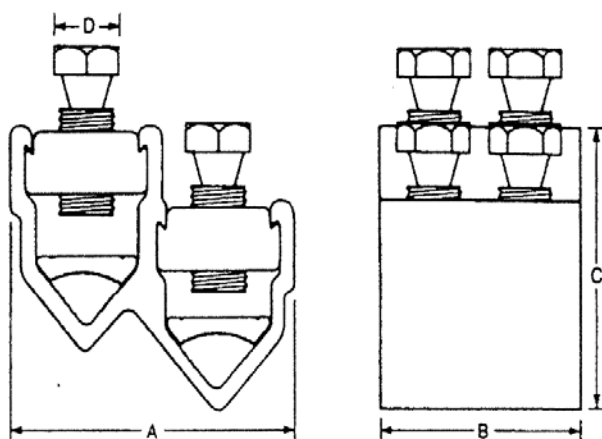
**Physical Dimensions**

Ref. Code	Dimensions (mm)			
	A	B	C	D
WB1	82	60	67	19
WB2	93	60	72	19
WB3	91	60	68	19

**Material**

Aluminium Alloy

**Fitting Instructions**

Separate the main cable cores sufficiently to allow the yoke section to be fitted around the conductor and strip the insulation from the core equal to the connector length plus 10mm. Thoroughly abrade the exposed conductor and loosely assemble the lower limb (mains side) of the connector around the core by fitting the bridge piece, inserting the pressure pad and tightening the main screws until the connector is positively located. Set and locate the branch core, then cut to length, strip insulation to suite and thoroughly abrade the exposed conductor before assembling into the connector as described above. Complete the operation by tightening down the mains screws consecutively, one turn at a time, until both heads shear, then repeating the operation for the branch screws.

If copper conductors are to be jointed, they should be wrapped in brass gauze in order to improve the electrical stability of the interface connection.