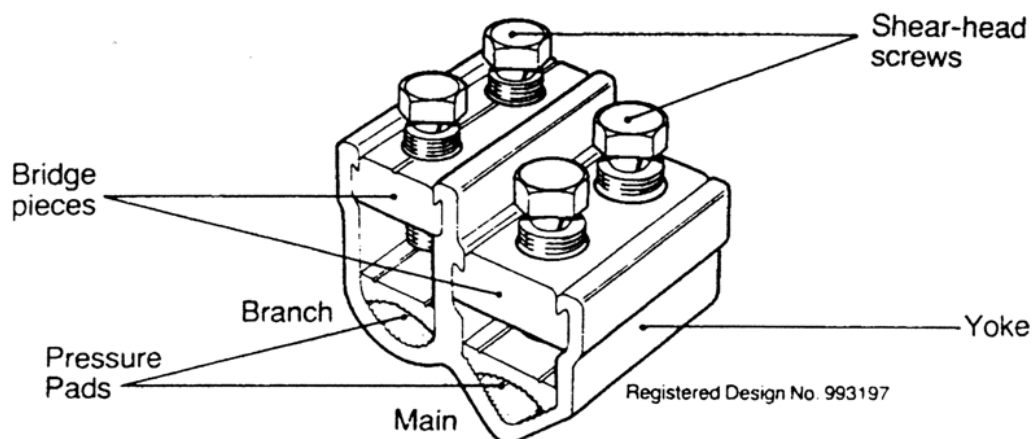

WB4 Connector**Principal Application**

Stranded sector shaped conductors

Range

Conenctor reference	Core c.s.a. (mm ²)				Approx Unit Wt. (grammes)
	Main		Branch		
	min.	max.	min.	max.	
WB4	150	300	185	300	410

The Hepworth WB4 connector is intended primarily for 4-core sector-shaped stranded cables, in both copper and aluminium with the branch channel designed to accept the branch conductor in any orientation to suit any particular joint configuration.

The Hepworth shear-head screws ensure that the correct clamping pressure is applied to give a reliable connection, eliminating the need for the use of specialised tools on site.

The connector is supplied individually packed, complete with fitting instructions, full details of which are included with the technical data overleaf. Brass gauze can be supplied upon request for use with copper conductors.

Secondary Applications

The WB4 is also suitable for stranded circular conductors to BS6360.

WB4 Connector**Range**

Conenctor reference	Core c.s.a. (mm ²)			
	Main		Branch	
	min.	max.	min.	max.
WB4	95	240	150	300

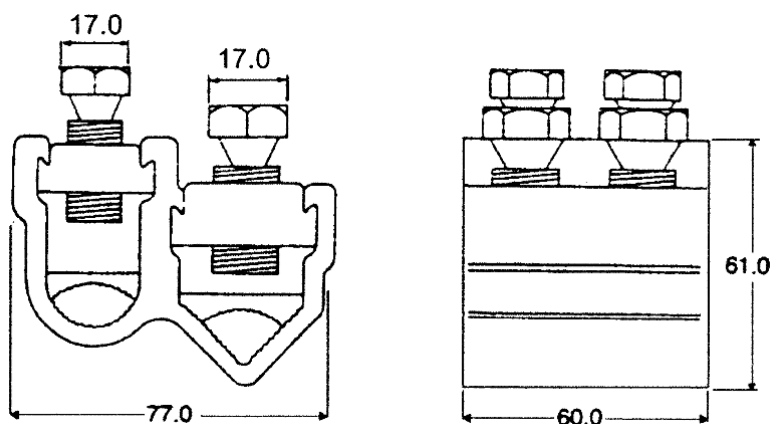
Physical Dimensions**Typical Performance Characteristics**

The WB4 connector has been designed to satisfy the test criteria specified in Electricity Association E.R. C79 and BS4579 where relevant.

Material

Aluminium Alloy

Fitting Instructions

Separate the main cable cores to enable the main channel of the connector to be fitted around the conductor. Strip a 70mm length of insulation (connector length plus 10mm) from the core at the selected connection position.

Thoroughly abrade the exposed section of the conductor, pass the lower channel (mains side) of the connector yoke around the conductor and loosely assemble by inserting the pressure-pad and bridge-piece. Tighten the screws until the connector is positively located on the main but do not shear off the screw heads at this stage.

Set the branch core and cut the required length. Strip the insulation to suit and thoroughly abrade the exposed conductor. Assemble as for the main connection.

Complete the operation by tightening the mains screws consecutively, one quarter of a turn at a time, until both heads are sheared. Repeat the operation for the branch side.

If copper conductors are to be jointed, they should be wrapped in brass gauze before insertion into the yoke.