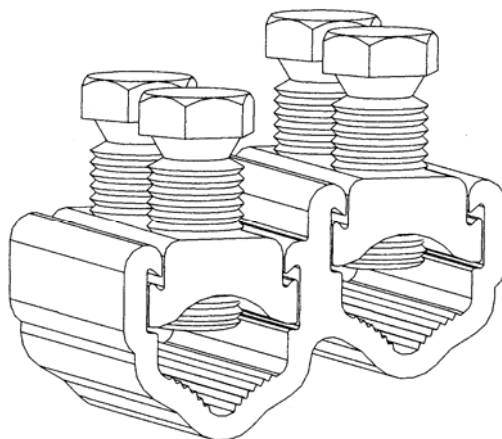

**WB95, WB95XL, WB185,
WB185XL, WB300 & WB300XL
Connectors**

Principle Application

For LV mains branch jointing of sector/round, stranded/solid, aluminium/copper conductor cores.

Range:

Connector Ref	Core csa (mm ²)				Approx Unit Weight (gms)
	Mains		Branch		
	Min	Max	Min	Max	
WB95	25	95	25	95	105
WB95XL					TBC
WB185	35	185	50	185	225
WB185XL					TBC
WB300	70	300	70	300	350
WB300XL					TBC

Note: For jointing other core configurations/sizes please contact Sicame Technical Department.

The **Hepworth WB95/WB95XL** range of mains branch connectors accommodates an extensive range of LV mains cable styles and sizes.

The connector utilises the proven shear head, direct acting bolts (plated) thereby removing the need for pressure plates.

The plated bolts, combined with a standard plated yoke section, allow for the joining of copper conductor cores without the need for conventional brass gauze.

Note: For the jointing of CNE strands add the suffix 'N' to the end of the product code, pressure pads will then be included.

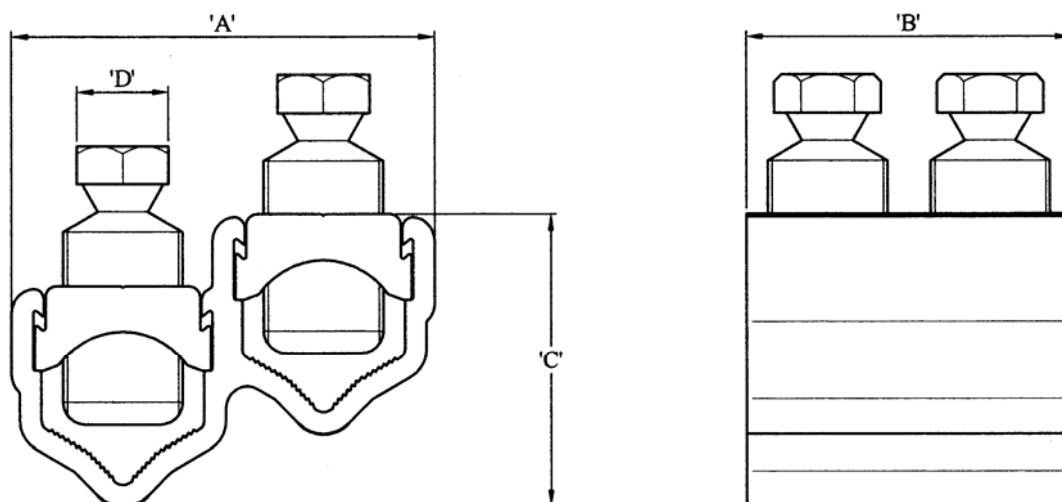
**WB95, WB95XL, WB185,
WB185XL, WB300 & WB300XL
Connectors**

Connector Reference	N° of Bridge Pieces Supplied	Dimensions (mm)			
		A	B	C	D
WB95	2	50.0	43.0	31.5	13 A/F
WB95XL	4		86.0		
WB185	2	67.0	54.0	44.0	17 A/F
WB185XL	4		108.0		
WB300	2	78.0	60.0	53.0	17 A/F
WB300XL	4		120.0		

Material

Aluminium Alloy

Test Specification

Designed to meet the requirements of Engineering Recommendation C79 and IEC 1238-1.