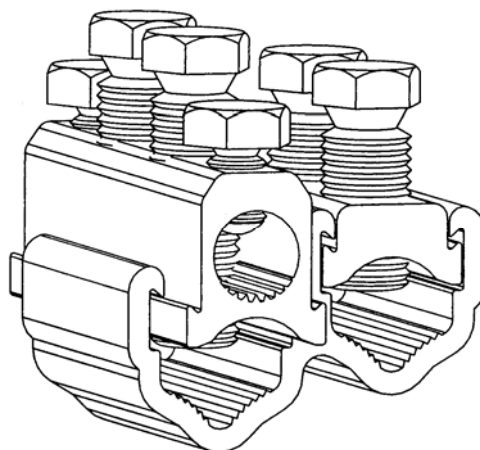

**WB95/S, WB185/S, WB300/S
Connectors**

Principle Application

For LV mains branch jointing (with services) of sector/round, stranded/solid, aluminium/copper conductor cores.

Range

Connector Ref	Core csa (mm ²)						Approx Unit Weight (gms)
	Mains		Branch		Service		
	Min	Max	Min	Max	Min	Max	
WB95/S	25	95	25	95	10*	70	235
WB185/S	35	185	50	185	10*	70	425
WB300/S	70	300	70	300	10*	70	605

Note: For jointing other core configurations/sizes please contact Sicame Technical Department.

The **Hepworth WB95/S** range of mains branch connectors accommodates an extensive range of LV mains cable cores whilst providing the facility for upto 2 service connections.

The connector utilises the proven shear head, direct acting bolts (plated) thereby removing the need for pressure plates.

The plated bolts, combined with a standard plated yoke section, allow for the jointing of mains copper conductor cores without the need for conventional brass gauze.

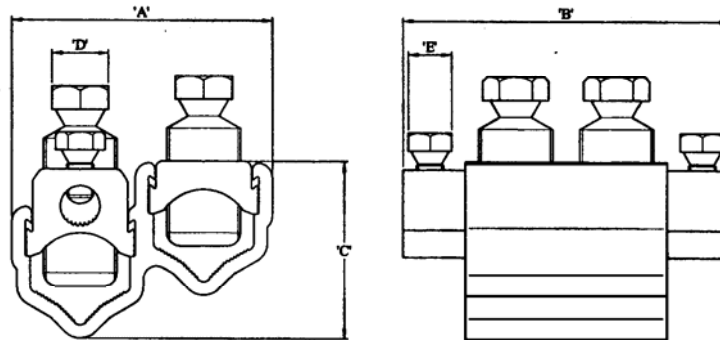
**WB95/S, WB185/S, WB300/S
Connectors****Physical Dimensions**

Connector Reference	Dimensions (mm)				
	A	B	C	D	E
WB95/S	50.0	79.0	36.5	13 A/F	13 A/F
WB185/S	67.0	90.0	44.5	17 A/F	13 A/F
WB300/S	78.0	98.0	53.0	17 A/F	13 A/F

Material

Aluminium Alloy, Copper Alloy (Service Shear Screw)

Test Specification

Designed to meet the requirements of Engineering Recommendation C79 and IEC 1238-1.

Stranded service conductor less than 10mm² should be doubled and re-doubled, where necessary, to achieve a satisfactory cross section area.