

WB95H/1SN
WB185H/1SN
WB300H/1SN
Connectors

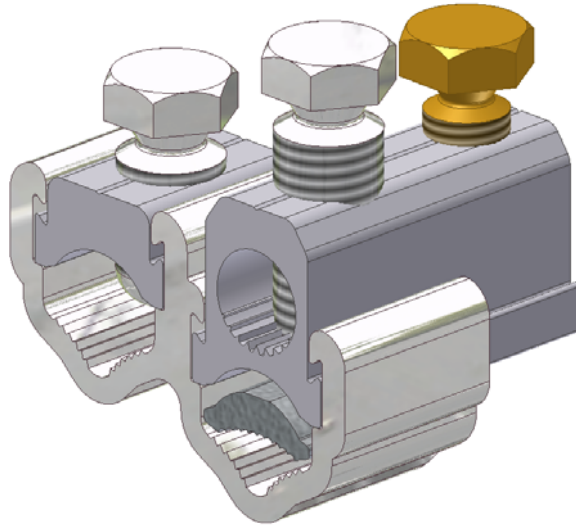

Principle Application

To facilitate the PME bonding within a 4 Core waveform stop end.

Range

Connector Ref	Core csa (mm ²)						Approx Unit Weight (gms)
	Neutral Core		Earth strands (Pressure Pad)		Earth Cable		
	Min	Max	Min	Max	Min	Max	
WB95H/1SN	25	95	70	95	10*	70	TBC
WB185H/1SN	35	185	70	185	10*	70	TBC
WB300H/1SN	70	300	95	300	10*	70	TBC

Note: For jointing other core configurations/sizes please contact Sicame Technical Department.

WB95H/1SN
WB185H/1SN
WB300H/1SN
Connectors

**Physical
Dimensions**

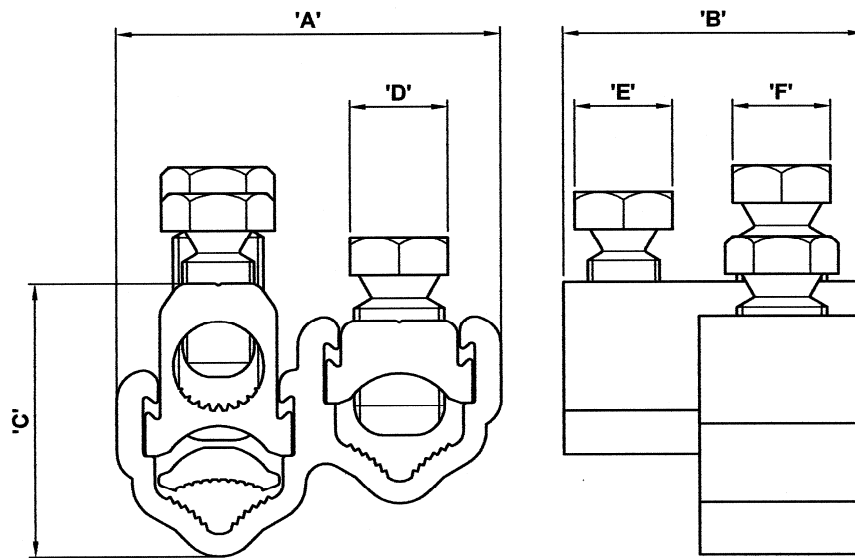

Connector Reference	Dimensions (mm)				
	A	B	C	D	E
WB95H/1SN	51.0	40.0	36.5	13 A/F	13 A/F
WB185H/1SN	67.0	46.0	44.5	17 A/F	13 A/F
WB300H/1SN	78.0	49.0	53.0	17 A/F	13 A/F

Material

Aluminium Alloy, Copper Alloy (Service Shear Screw)

Test Specification

Designed to meet the requirements of Engineering Recommendation C79 and IEC 1238-1.