

WS4 Connector

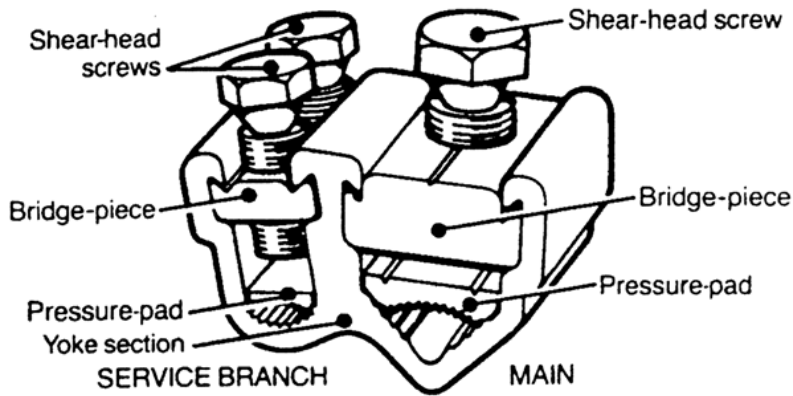

Registered Design No. 993196

Principal Application

Double service connections from stranded sector shaped mains conductors.

Range

Connector reference	Core c.s.a. (mm ²)				Approx Unit Wt. (grammes)
	Main		Service Branch		
	min.	max.	min.	max.	
WS4	240	300	2 x 50	2 x 95	260

The Hepworth WS4 connector has been designed to accommodate a double service configuration to a maximum of two 95mm² stranded conductors, off four-core stranded sector shaped mains conductors in the range 240-300mm².

The connector employs the proven shear-head screw principle to ensure that a consistent and reliable connection is achieved. Fitting is completed by the use of orthodox hand tools only, and no specialised equipment or techniques are required.

Each connector is supplied in a sealed pack together with fitting instructions, details of which are included in the technical data overleaf.

WS4 Connector**Secondary Applications**

(a) Single Branch Connections. The WS4 connector is also suitable for single branch connections in the range 95-185mm² (sector shaped conductors).

(b) Circular Conductors. The WS4 can accept stranded circular conductors to BS6360 (copper) and BS6791 (aluminium), in the mains and/or branch sides of the connector in the following ranges: -

Connector reference	Core c.s.a. (mm ²)			
	Main		Service Branch	
	min.	max.	min.	max.
WS4	120	185	1 x 50 or 2 x 35	1 x 150 or 2 x 70

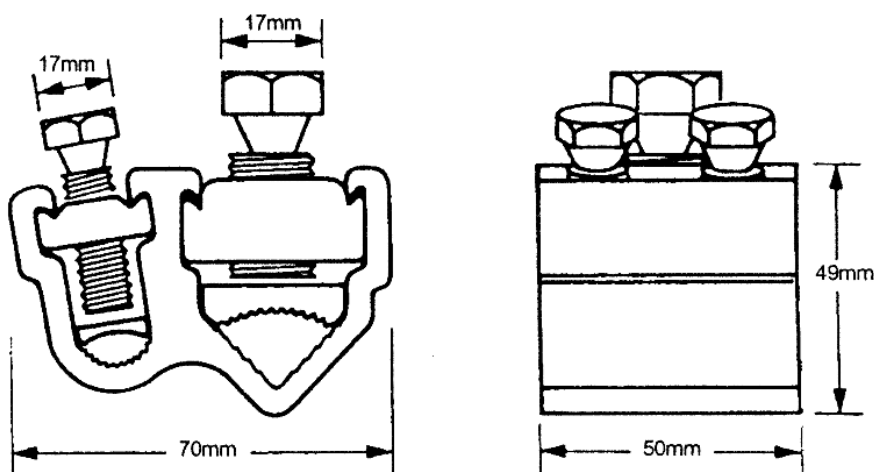
Physical Dimensions**Material**

Aluminium Alloy

Fitting Instructions

Separate the main cable cores sufficiently to allow the yoke section to be fitted around the conductor and strip the insulation from the core equal to the connector length plus 10mm. Thoroughly abrade the exposed conductor and loosely assemble the connector around the core by fitting the bridge piece, inserting the pressure pad and tightening the mains screw until the connector is positively located. Cut the branch conductor to length, strip the insulation to suit, then thoroughly abrade and assemble the core into the connector by fitting the bridge piece and pressure pad, and tightening down the service screws to hold the conductors in position. Complete the operation by tightening down the mains screws until the head shears, then finally tightening the service screws consecutively, one turn at a time, until both heads are sheared.

If copper conductors are to be jointed, they should be wrapped in brass gauze in order to improve the electrical stability of the interface connection.