

Straight-through mains connectors (with single / double service)

## MECHANICAL CONNECTORS

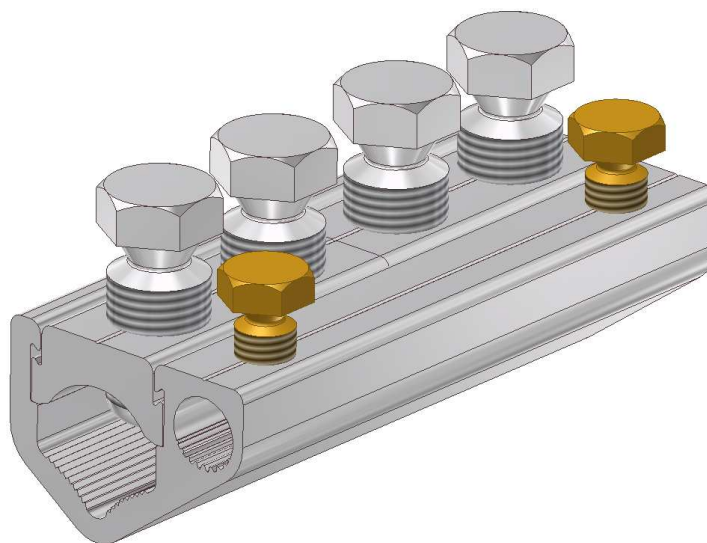

### UM95/2SS, UM185/2SS & UM300/2SS Connectors



#### Principle Application:

For LV straight jointing of sector/round, stranded/solid, aluminium/copper conductor cores with facility for single or double service.

#### Range:

Connector Reference	Core C.S.A. (mm <sup>2</sup> )			
	Mains		Service	
	Min.	Max.	Min.	Max.
UM95/2SS	25	95	10*	70
UM185/2SS	35	185	10*	70
UM300/2SS	70	300	10*	70

Note: For jointing other core configurations/sizes please contact Sicame Technical Dept

The **Hepworth UMxxx/2SS** ..... range of straight through mains connectors accommodates an extensive range of LV cable styles and sizes combined with the facility for a single or double service connection.

The connector utilises the proven shear head, direct acting bolts (plated) thereby removing the need for pressure plates.

The plated bolts, combined with a standard plated yoke section, allow for the jointing of copper conductor cores without the need for conventional brass gauze.

**Note:** For the jointing of CNE strands add the suffix 'N' to the end of the product code, pressure pads will then be included.

Straight-through mains connectors (with single / double service)

## MECHANICAL CONNECTORS

### UM95/2SS, UM185/2SS & UM300/2SS Connectors

#### Physical Dimensions

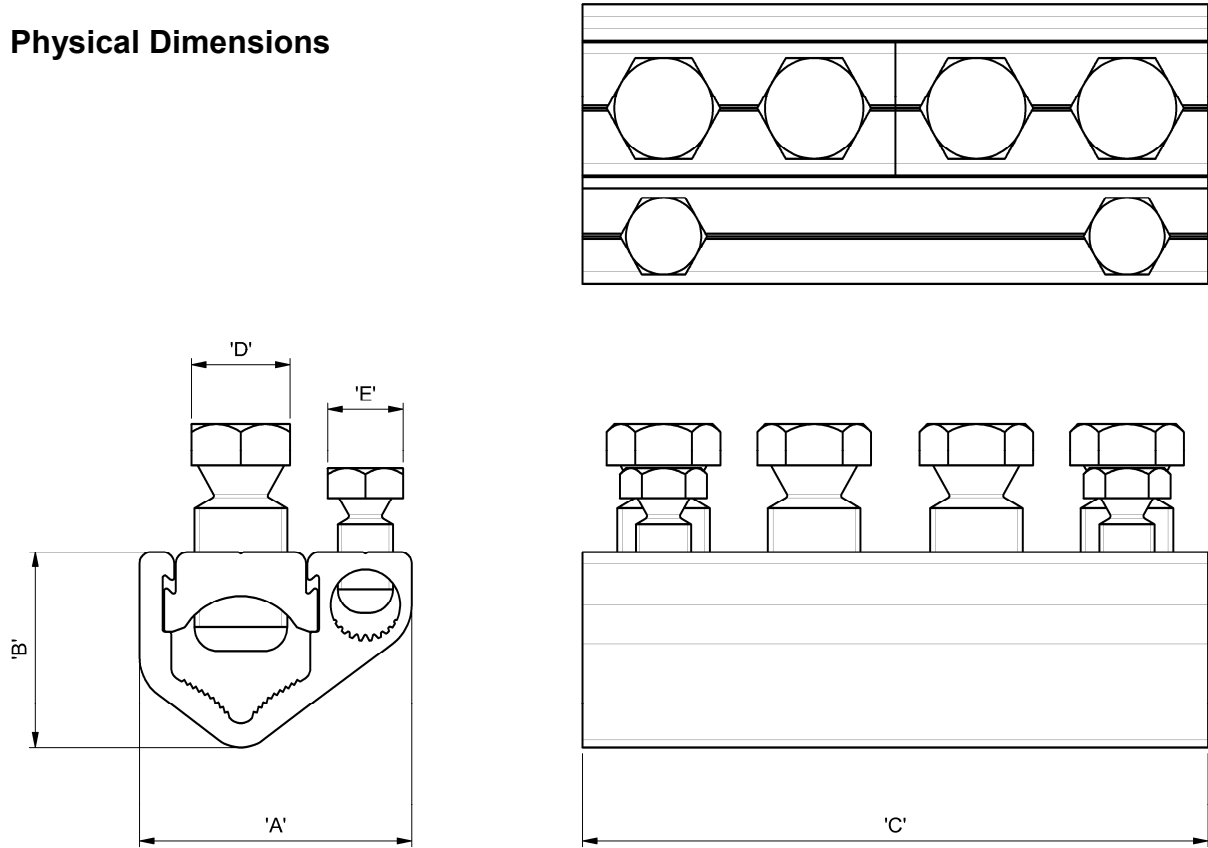

Connector Reference	Dimensions (mm)				
	'A'	'B'	'C'	'D'	'E'
UM95/2SS	39.5	25.0	86.0	13 A/F	13 A/F
UM185/2SS	47.0	33.0	108.0	17 A/F	13 A/F
UM300/2SS	53.0	39.5	120.0	17 A/F	13 A/F

#### Material:

Aluminium Alloy (Plated)  
Brass (Service Shear Bolts)

#### Test Specification:

Designed to meet the requirements of Engineering Recommendation C79 and IEC 1238-1.