

MF4 Connectors - Heat Shrink Section

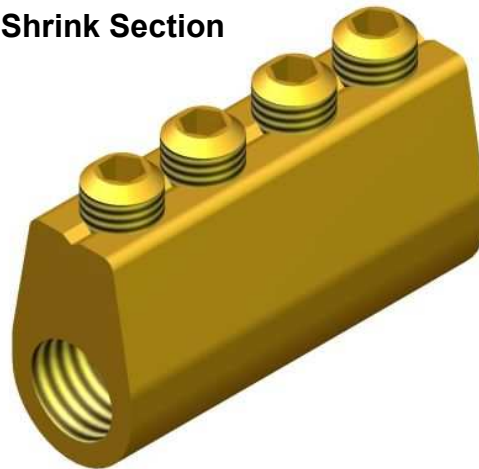

Principle Application:

Stranded and solid shaped service conductors.

Range:

Product Reference	Type	Core C.S.A. (mm ²)	
		Min	Max
MF4/5	Straight Through	6*	16
MF4/6	Moisture Blocked		
MF4/7	Straight Through	16	50
MF4/8	Moisture Blocked		
MF4/15	Straight Through	16	70
MF4/16	Moisture Blocked		
MF4/22	Moisture Blocked	70	70

Note: For jointing other core configurations/sizes please contact Sicame Technical Dept

The **Hepworth MF4** range of mechanical connectors are designed for straight connections on stranded or solid service cables. The ferrules are manufactured in brass for suitability of jointing copper/aluminium, sector/circular shaped conductors.

This particular range of mechanical ferrules have been specifically designed for joints where a cold or heat shrink sleeving is a requirement.

MF4 Connectors - Heat Shrink Section

Secondary Application:

Stranded and solid circular conductors.

Range:

Product Reference	Type	Maximum Core C.S.A. (mm ²)	
		Solid	Stranded
MF4/5	Straight Through	35	35
MF4/6	Moisture Blocked		
MF4/7	Straight Through	70	50
MF4/8	Moisture Blocked		
MF4/15	Straight Through	95	70
MF4/16	Moisture Blocked		
MF4/22	Moisture Blocked	70	70

* Note: Conductors below 6mm² should be doubled and, if necessary, doubled again to achieve a satisfactory cross sectional area.

Physical Dimensions:

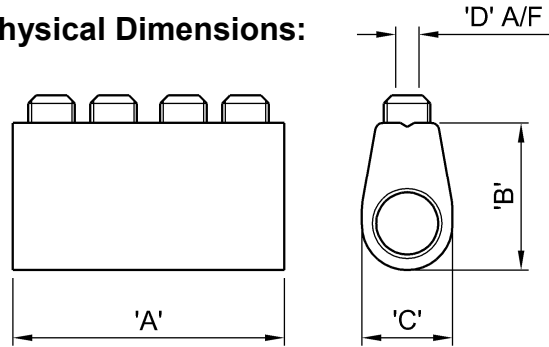

* MF4/22 - 4 x Shear Screws

Product Reference	Dimensions (mm)			
	'A'	'B'	'C'	'D'
MF4/5	35.0	19.0	11.7	3.0
MF4/6	44.0	19.0	11.7	3.0
MF4/7	45.0	22.0	17.0	3.0
MF4/8	55.0	22.0	17.0	3.0
MF4/15	55.0	22.0	17.0	5.0
MF4/16	65.0	22.0	17.0	5.0
MF4/22*	80.0	25.0	23.0	13.0

Material:

Copper Alloy

Test Specifications:

BS4579 : Pt 1 : 1970, BS4579 : Pt 3 : 1976

Fitting Instructions:

1. Cut the service cables to length and strip the core insulation equal to half the length of connector + 3mm.
2. Thoroughly abrade all conductors to be jointed.
3. Align cores within connector and tighten screws on each side of the connector consecutively, until tight.