

ML Connectors

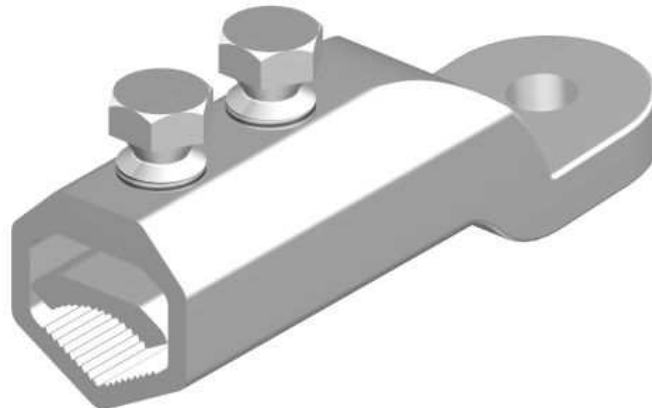

Principle Application

Termination of sector shaped stranded or solid cored conductors.

Range

Product Reference	Core c.s.a. (mm ²)		Stud Size	
	Min	Max	Metric	Imperial
ML1-12	50	95	M12	1/2"
ML1-16			M16	5/8"
ML2-12	120	185	M12	1/2"
ML2-16			M16	5/8"
ML3-12	240	300	M12	1/2"
ML3-16			M16	5/8"
ML3-20			M20	3/4"

Note: For jointing other core configurations/sizes please contact Sicame Technical Dept

The **Hepworth 'ML'** range of mechanical lugs has been designed as a practical alternative to crimping or sweating methods, thereby offering the following advantages: -

- a. Terminations can be jointed using simple hand tools, therefore specialised tooling or sweating skills are not required.
- b. The bolted connection to the busbar, or any other equipment, can be accurately located before the conductor is finally secured within the barrel of the lug, thereby avoiding any problems of elongation and axial alignment.
- c. The mechanical lugs have been short circuit tested, and are suitable for LV/MV applications.

ML Connectors

Physical Dimensions

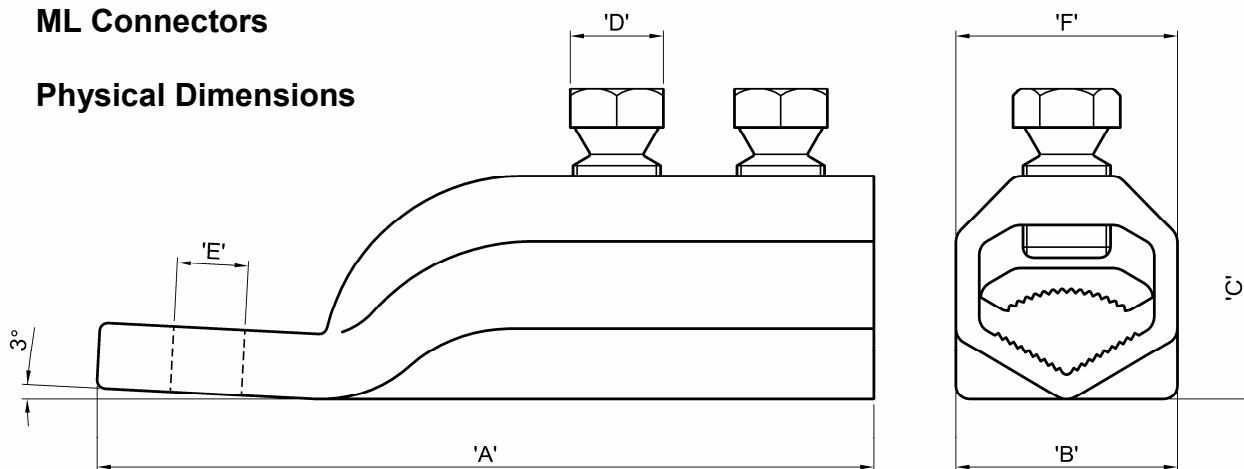

Product Reference	Dimensions (mm)					
	'A'	'B'	'C'	'D' A/F	'E'	'F'
ML1-12	95.0	32.0	25.0	17.0	13.0	25.0
ML1-16					17.0	
ML2-12	125.0	34.0	32.5	17.0	13.0	34.0
ML2-16					17.0	
ML3-12	145.0	40.0	41.0	17.0	13.0	40.0
ML3-16					17.0	
ML3-20					22.0	

Material

Aluminium Alloy

Test Specification

BS4579 including short-circuit tests Engineering Recommendation C79

Fitting Instructions

- Strip insulation from core equal to length of pressure pad + 5mm.
- Thoroughly abrade exposed conductors.
- Wrap brass gauze around any copper conductors within the connector.
- Slacken screws and fit lug over core and fully insert pressure pad.
- Tighten screws consecutively one turn at a time until the heads have sheared.