

Universal Mains/Service
Termination Connector

MECHANICAL CONNECTORS

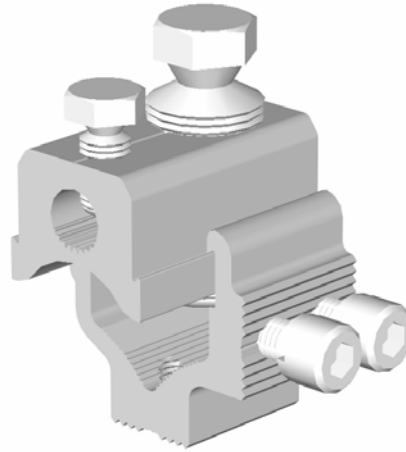

UMT95S, UMT185S & UMT300S Connectors



Principle Application

For LV mains/service terminations of sector/round, stranded/solid aluminium/copper conductor cores.

Range

Connector Reference	Mains (mm ²)		Service (mm ²)		Approx Unit Weight (grms)
	Min	Max	Min	Max	
UMT95S	25	95	10*	70	
UMT185S	35	185	10*	70	
UMT300S	70	300	10*	70	

Note: For jointing other core configurations/sizes please contact Sicame Technical Dept

The **Hepworth UMT/S** range of universal mains/service termination connectors accommodates an extensive range of LV cable styles and sizes.

The connector utilises the proven shear head direct acting bolts (plated) thereby removing the need for pressure plates.

The plated bolts, combined with a standard plated yoke section, allow for the jointing of mains copper conductor cores without the need for conventional brass gauze.

**UMT95S, UMT185S & UMT300S
Connectors**

Physical Dimensions

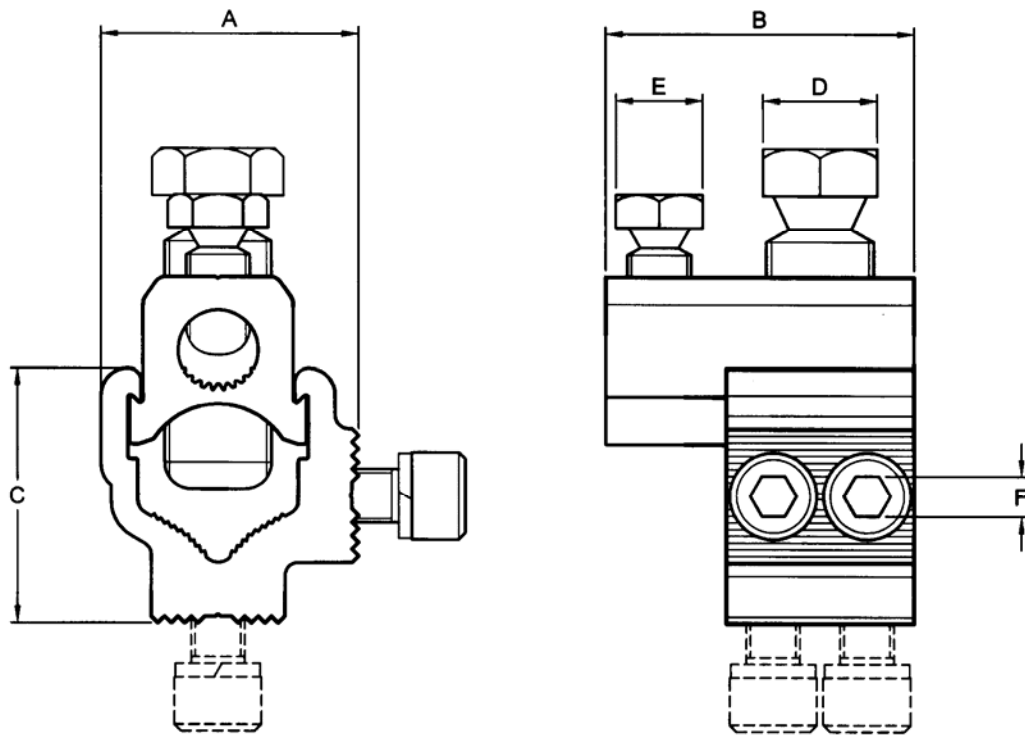

Connector Reference	Dimensions (mm)					
	A	B	C	D	E	F
UMT95S	30.5	43.0	30.5	13 A/F	13 A/F	5 A/F
UMT185S	38.5	46.0	38.0	17 A/F	13 A/F	6 A/F
UMT300S	44.5	49.0	44.5	17 A/F	13 A/F	6 A/F

Material

Aluminium Alloy

Test Specification

Designed to meet the requirements of Engineering Recommendation C79, BS4579 and IEC1238-1.