

**UMT95XL, UMT185XL & UMT300XL
Connectors**

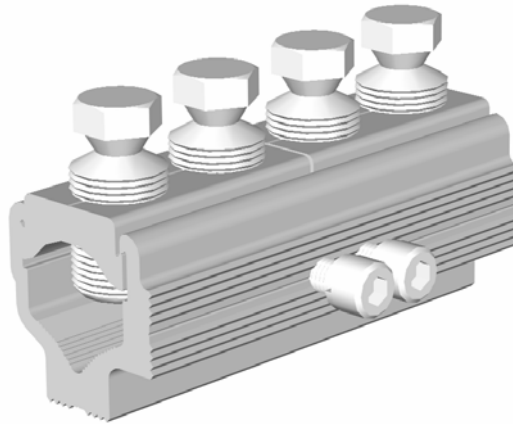

Principle Application

For LV terminations of sector/round, stranded/solid, aluminium/copper conductor cores.

Range

Connector Reference	Core csa (mm ²)		Approx Unit Weight (grms)
	Min	Max	
UMT95XL	25	95	
UMT185XL	35	185	
UMT300XL	70	300	

Note: For jointing other core configurations/sizes please contact Sicame Technical Dept

The **Hepworth UMT/XL** range of universal termination connectors accommodates an extensive range of LV cable styles and sizes.

The connector utilises the proven shear head direct acting bolts (plated) thereby removing the need for pressure plates.

The plated bolts, combined with a standard plated yoke section, allow for the jointing of copper conductor cores without the need for conventional brass gauze.

**UMT95XL, UMT185XL & UMT300XL
Connectors**

Physical Dimensions

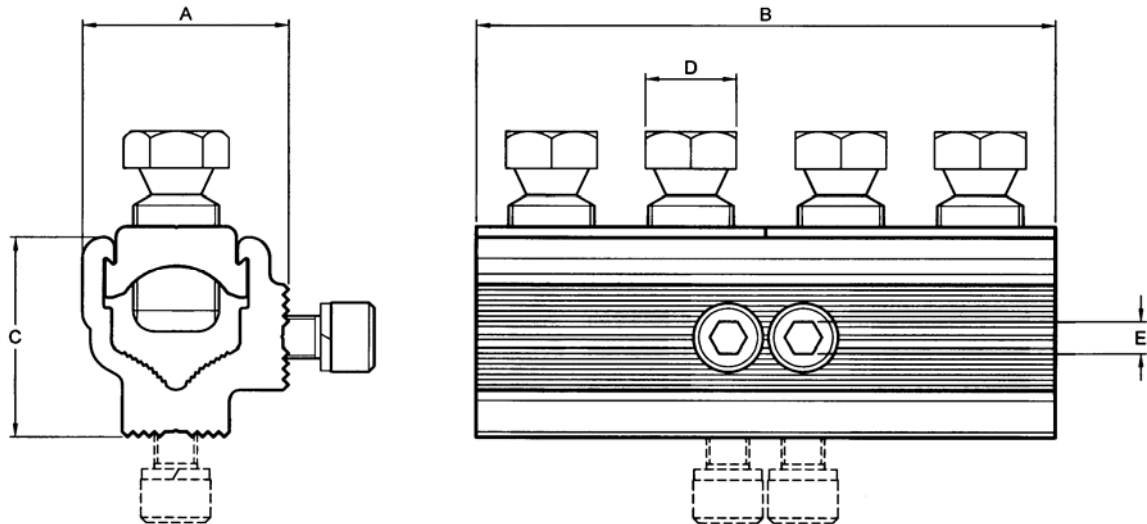

Connector Reference	Dimensions (mm)				
	A	B	C	D	E
UMT95XL	30.5	86.0	30.5	13 A/F	5 A/F
UMT185XL	38.5	108.0	38.0	17 A/F	6 A/F
UMT300XL	44.5	120.0	44.5	17 A/F	6 A/F

Material

Aluminium Alloy

Test Specification

Designed to meet the requirements of Engineering Recommendation C79, BS4579 and IEC1238-1.