

- Mains Straight Connector
- Mains Branch

## MECHANICAL CONNECTORS

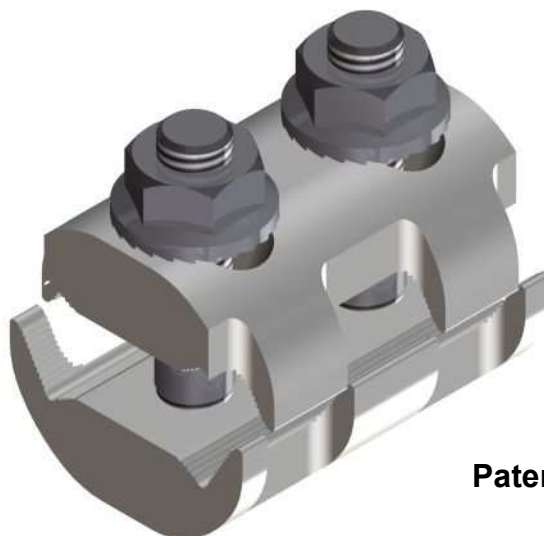

### LVM Connector



Patent No: GB 2311662

#### Principle Application:

- ESI 09-8 : Impregnated Paper-Insulated 600/1000 Volt (CONSAC)
- ESI 09-9 : Polymeric Insulated, Combined Neutral/Earth (Waveform)
- BS6346 : PVC Insulated 600/1000 Volt Cable
- BS6480 : Impregnated Paper Insulated Lead or Lead Alloy (PILC)

#### Range:

| Connector Reference | Core C.S.A. (mm <sup>2</sup> ) |     |              |     |
|---------------------|--------------------------------|-----|--------------|-----|
|                     | Mains                          |     | Mains/Branch |     |
|                     | Min                            | Max | Min          | Max |
| LVM 1               | 70 (1)                         | 95  | 70 (1)       | 95  |
| LVM 2               | 70 (1)                         | 185 | 70 (1)       | 185 |
| LVM 3               | 70 (1)                         | 300 | 70 (1)       | 300 |

Note: For jointing other core configurations/sizes please contact Sicame Technical Dept

The Hepworth **LVM...** range of connectors has been designed to provide the end user with a cost effective and safe method of jointing all types of LV cables, particularly, in a live 'on-load' jointing situation using a single range of profiled mechanical connectors.

The LVM range of connectors have been tested and witnessed (EA Technology) to confirm their ability to pick up 600 Amps @ 240V.

The LVM connectors are also suitable for jointing an extensive range of LV cables including aluminium or copper, solid or stranded, shaped or circular (service) conductor cores.

#### Accessories:

- LV Fitted Insulation Shroud for:-
- LVM 1 - Part No: 4346 + ties (x3)
- LVM 2 - Part No: 4349 + ties (x3)
- LVM 3 - Part No: 4352 + ties (x3)

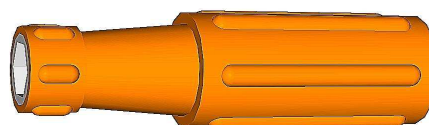

'JTS/21' Insulated Nut Runner

(See Technical Data Sheet 8.09 for product specification)

- Mains Straight Connector
- Mains Branch

## MECHANICAL CONNECTORS

### LVM Connector

#### Physical Dimensions

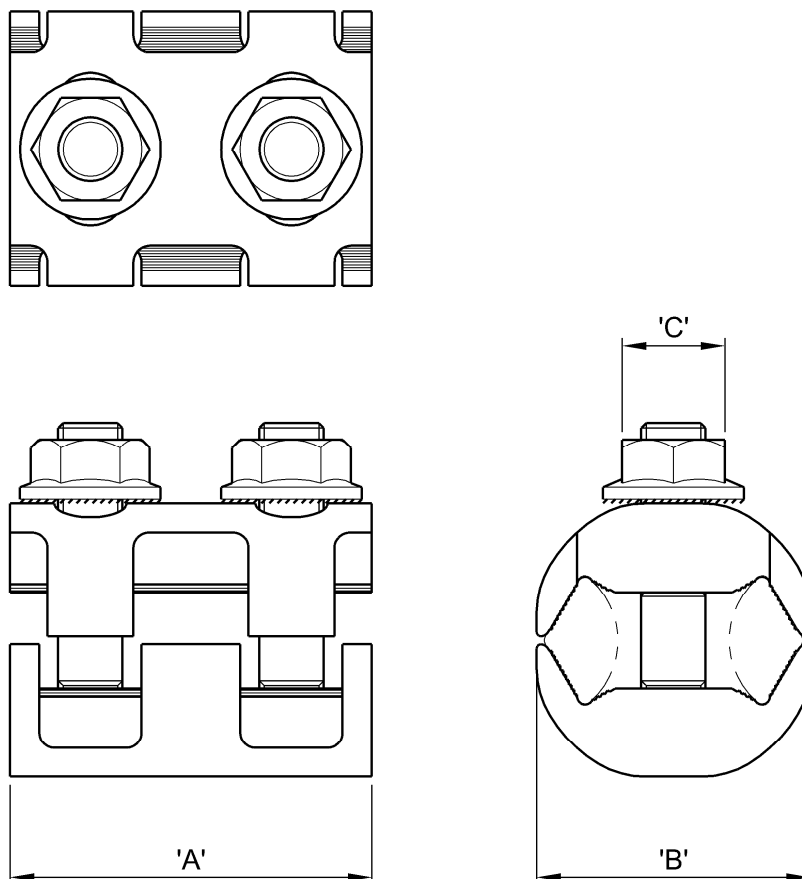

| Connector Reference | Dimensions (mm) |     |        |
|---------------------|-----------------|-----|--------|
|                     | 'A'             | 'B' | 'C'    |
| LVM 1               | 45              | 34  | 13 A/F |
| LVM 2               | 45              | 44  | 13 A/F |
| LVM 3               | 50              | 54  | 13 A/F |

#### Material:

Aluminium Alloy (Electro-Tinned)

#### Note:

1. Conductor cores of less than 70mm<sup>2</sup> can be jointed by doubling and re-doubling, where necessary, to achieve a satisfactory cross sectional area.
2. Electro-tinned surface negates the requirement for brass gauze.