

- Mains Service Connector
- Service / Service

MECHANICAL CONNECTORS



LVS Connector



Patent No: GB 2311662

Principle Application:

- ESI 09-7 : PVC Insulated Concentric Service Cable
- ESI 09-8 : Impregnated Paper-Insulated 600/1000 Volt (CONSAC)
- ESI 09-9 : Polymeric Insulated, Combined Neutral/Earth (Waveform)
- BS6346 : PVC Insulated 600/1000 Volt Cable
- BS6480 : Impregnated Paper Insulated Lead or Lead Alloy (PILC)

Range:

Connector Reference	Core C.S.A. (mm ²)			
	Mains/Service (1)		Service (1)	
	Min	Max	Min	Max
LVS 1	16 (1)	95	16 (1)	35
LVS 2	16 (1)	185	16 (1)	35
LVS 3	16 (1)	300	16 (1)	35

Note: For jointing other core configurations/sizes please contact Sicame Technical Dept

The Hepworth **LVS...** range of connectors has been designed to provide the end user with a cost effective method of jointing all types of LV cables using a single range of profiled mechanical connectors.

The LVS connectors are suitable for jointing an extensive range of LV cables including aluminium or copper (2), solid or stranded, shaped or circular (service) conductor cores.

Accessories:

- LV Fitted Insulation Shroud for:-
- LVS 1 - Part No: 4345 + ties (x2)
- LVS 2 - Part No: 4348 + ties (x2)
- LVS 3 - Part No: 4351 + ties (x2)

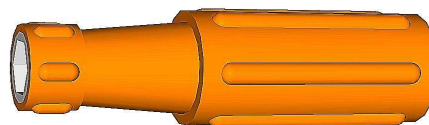

'JTS/21' Insulated Nut Runner

(See Technical Data Sheet 8.09 for product specification)

- Mains Service Connector
- Service / Service

MECHANICAL CONNECTORS

LVS Connector

Physical Dimensions

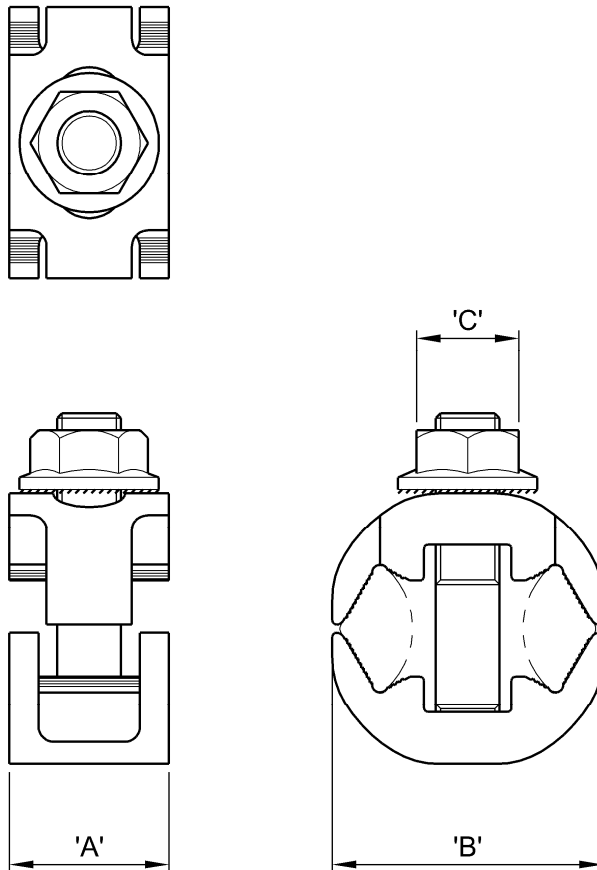

Connector Reference	Dimensions (mm)		
	'A'	'B'	'C'
LVS 1	20	34	13 A/F
LVS 2	20	44	13 A/F
LVS 3	22	54	13 A/F

Material:

Aluminium Alloy (Electro-Tinned)

Note:

1. Stranded service conductor of 16mm² or below should be doubled and re-doubled, where necessary, to achieve a satisfactory cross sectional area.
2. Electro-tinned surface negates the requirement for brass gauze.