

- Mains Double Service

## MECHANICAL CONNECTORS

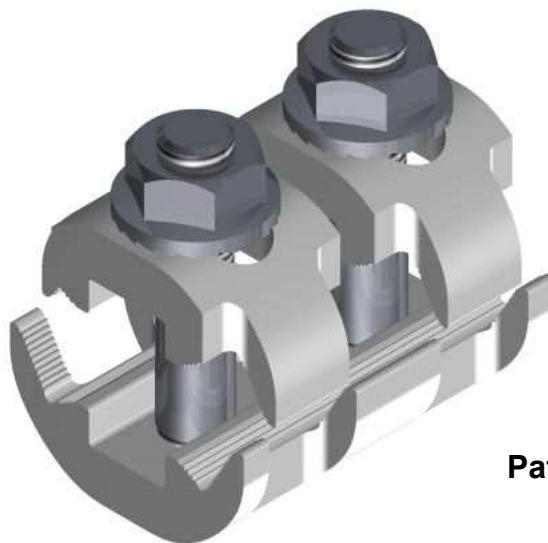

### LVMS Connector



Patent No: GB 2311662

#### Principle Application:

- ESI 09-7 : PVC Insulated Concentric Service Cable
- ESI 09-8 : Impregnated Paper-Insulated 600/1000 Volt (CONSAC)
- ESI 09-9 : Polymeric Insulated, Combined Neutral/Earth (Waveform)
- BS6346 : PVC Insulated 600/1000 Volt Cable
- BS6480 : Impregnated Paper Insulated Lead or Lead Alloy (PILC)

#### Range:

Connector Reference	Core C.S.A. (mm <sup>2</sup> )			
	Mains/Service (1)		Service (1)	
	Min	Max	Min	Max
LVMS 1	16 (1)	95	16 (1)	35
LVMS 2	16 (1)	185	16 (1)	35
LVMS 3	16 (1)	300	16 (1)	35

Note: For jointing other core configurations/sizes please contact Sicame Technical Dept

The Hepworth **LVMS...** range of connectors has been designed to provide the end user with a cost effective method of jointing all types of LV cables using a single range of profiled mechanical connectors.

The LVMS connectors provide the facility for 1 or 2 x service connections off an extensive range of LV cables including aluminium or copper, solid or stranded, shaped or circular (service) conductor cores.

#### Accessories:

- LV Fitted Insulation Shroud for:-
- LVMS 1 - Part No: 4346 + ties (x3)
- LVMS 2 - Part No: 4349 + ties (x3)
- LVMS 3 - Part No: 4352 + ties (x3)

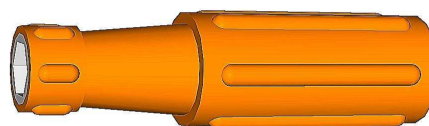

'JTS/21' Insulated Nut Runner

(See Technical Data Sheet 8.09 for product specification)

- Mains Double Service

## MECHANICAL CONNECTORS

### LVMS Connector

#### Physical Dimensions

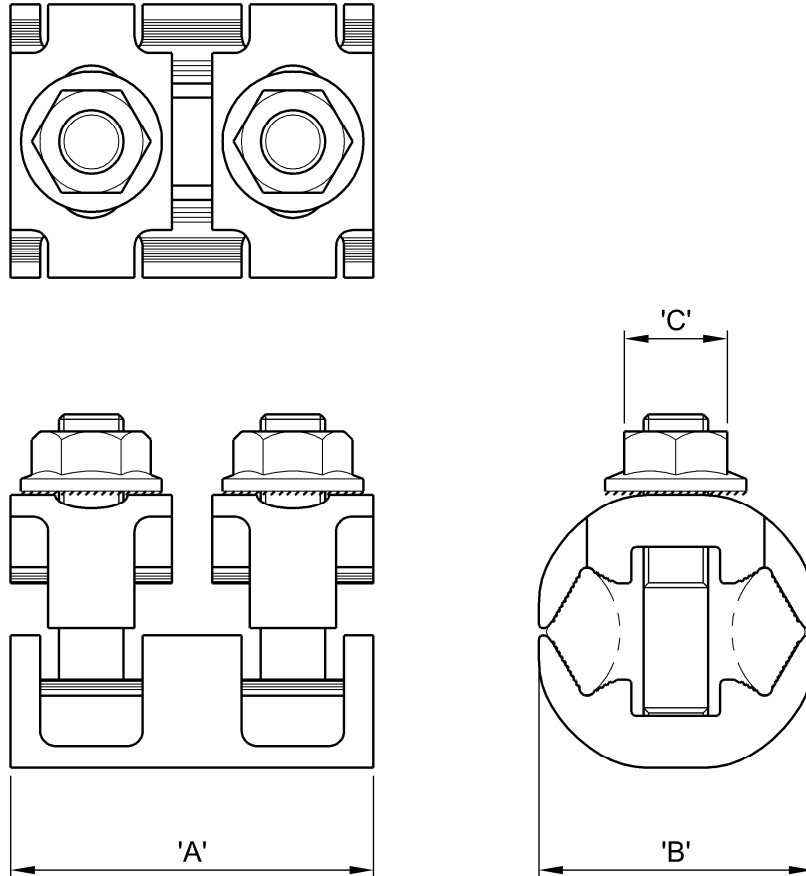

Connector Reference	Dimensions (mm)		
	'A'	'B'	'C'
LVMS 1	45	34	13 A/F
LVMS 2	45	44	13 A/F
LVMS 3	50	54	13 A/F

#### Material:

Aluminium Alloy (Electro-Tinned)

#### Note:

1. Stranded service conductor of 16mm<sup>2</sup> or below should be doubled and re-doubled, where necessary, to achieve a satisfactory cross sectional area.
2. Electro-tinned surface negates the requirement for brass gauze.