

LVM.../C Connectors

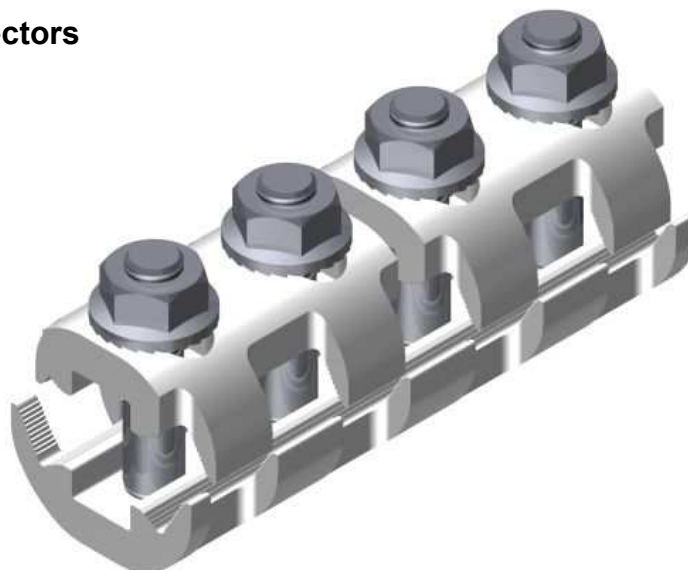

Principle Application:

- ESI 09-7: PVC Insulated Concentric Service Cable
- ESI 09-8: Impregnated Paper-Insulated 600/1000 Volt (CONSAC)
- ESI 09-9: Polymeric Insulated, Combined Neutral/Earth (Waveform)
- BS6346: PVC Insulated 600/1000 Volt Cable
- BS6480: Impregnated Paper Insulated Lead or Lead Alloy (PILC)

Range:

Connector Reference	Core C.S.A. (mm ²)			
	Mains		Mains / Branch	
	Min	Max	Min	Max
LVM1/C	70 (1)	95	70 (1)	95
LVM2/C	70 (1)	185	70 (1)	185
LVM3/C	70 (1)	300	70 (1)	300

Note: For jointing other core configurations/sizes please contact Sicame Technical Dept

The Hepworth **LVM.../C** range of connectors has been designed to provide the end user with a cost effective and safe method of jointing all types of LV cables, particularly, in a live 'on-load' jointing situation using a single range of profiled mechanical connectors.

The LVM.../C connectors are suitable for jointing an extensive range of LV cables including aluminium or copper, solid or stranded, shaped or circular (service) conductor cores.

Accessories:

- LV Fitted Insulation Shroud for:-
- LVM1/C - 250mm x 200mm CR Sheet
- LVM2/C - 250mm x 200mm CR Sheet
- LVM3/C - 250mm x 250mm CR Sheet

LVM.../C Connectors

Physical Dimensions

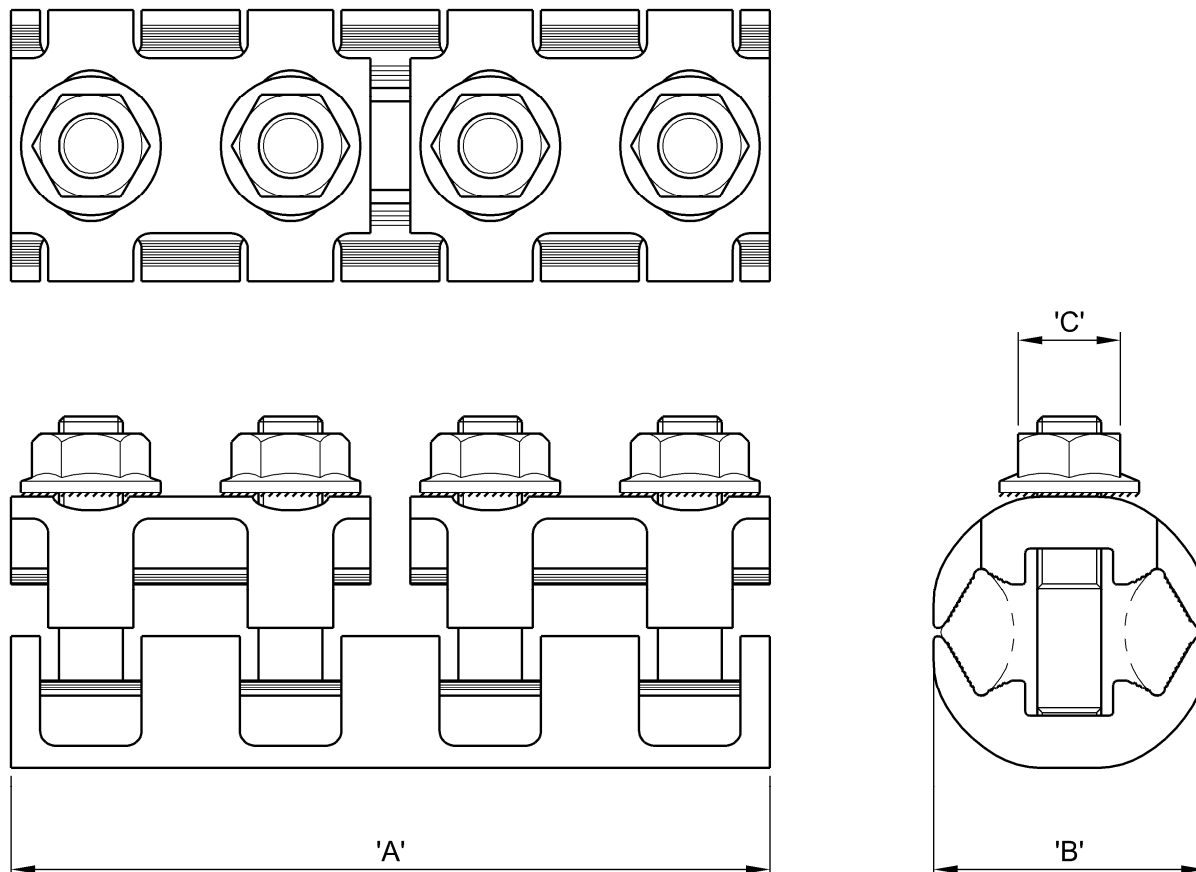

Connector Reference	Dimensions (mm)		
	'A'	'B'	'C'
LVM1/C	95	34	13 A/F
LVM2/C	95	44	13 A/F
LVM3/C	106	54	13 A/F

Material:

Aluminium Alloy (Electro-Tinned)

Note:

1. Conductor cores of less than 70mm² can be jointed by doubling and re-doubling, where necessary, to achieve a satisfactory cross sectional area.
2. Electro-tinned surface negates the requirement for brass gauze.