

Mechanical In-Line Splice
with Moisture/Contaminant
Block for Medium/High
Voltage Applications

MECHANICAL CONNECTORS

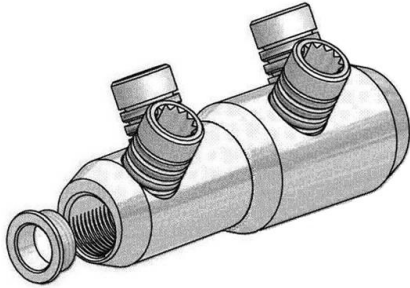

'USMF' Aluminium In-Line Splices



USMF5

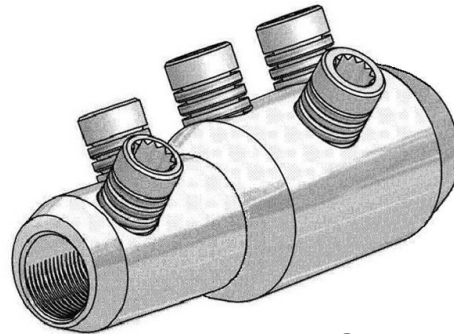

**USMF4
USMF6**

Principle Application:

Straight jointing of circular stranded aluminium or copper conductors for all cable voltages up to and including 46kV.

Range:

Connector Reference	Stranded Core Size			
	Min	Max	Min	Max
USMF4	1/0 (53mm ²)	500 kcmil (253mm ²)	500 kcmil (253mm ²)	1000 kcmil (507mm ²)
USMF5*	# 2 (34mm ²)	250 kcmil (127mm ²)	4/0 (107mm ²)	500 kcmil (253mm ²)
USMF6	4/0 (107mm ²)	350 kcmil (177mm ²)	350 kcmil (177mm ²)	750 kcmil (380mm ²)

The '**USMF**' range of mechanical connectors incorporate an integral moisture/contaminant block and utilise the patented universal range taking shear bolts. (USA Patent No's 6209424 & 6321624)

The appropriate tooling is to be used at all times, typical examples shown below.

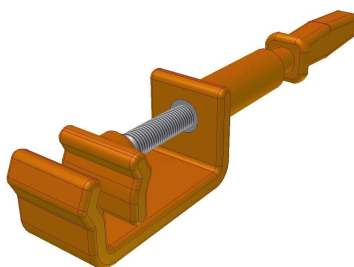

'JTS/22' Holding Tool



'JTS/9' 1/2" sq Driver

Mechanical In-Line Splice
with Moisture/Contaminant
Block for Medium/High
Voltage Applications

‘USMF’ Aluminium In-Line Splices

Physical Dimensions:

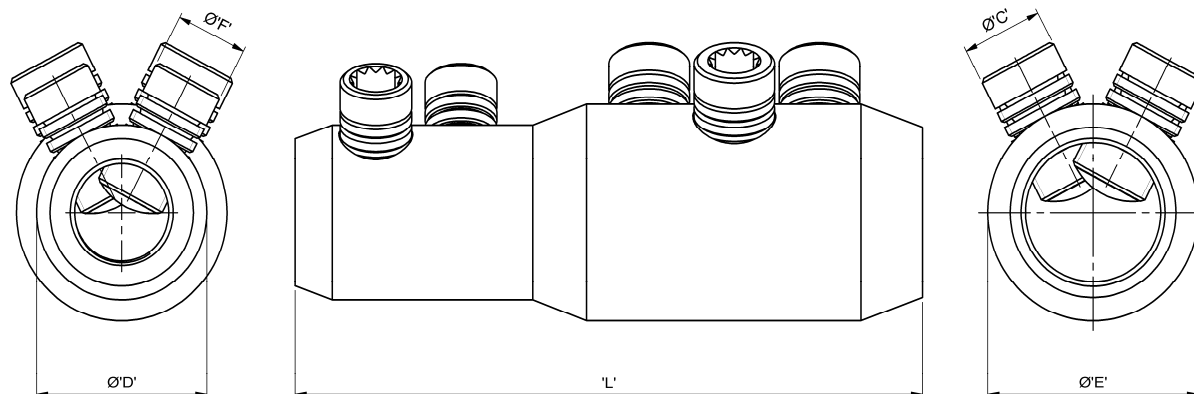

Connector Reference	Dimensions				
	'L'	'ØC'	'ØD'	'ØE'	'ØF'
USMF4	5.51" (140mm)	M18	1.50" (38mm)	1.85" (47mm)	M16
USMF5*	4.33" (110mm)	M16	1.14" (29mm)	1.34" (34mm)	M16
USMF6	5.33" (135.5mm)	M18	1.25" (32mm)	1.47" (37.5mm)	M16

Material: Aluminium Alloy (Electro-Tinned)

Test Specification: ANSI C119.4 Class 2 Partial Tension

Test Report No: TTR/271 & TTR/272

Fitting instructions:

1. Strip insulation from each core equal to the depth of the bore.
2. Wire brush the exposed conductor cores and wipe clean (optional).
3. Align and position the conductor cores in each of the bores ensuring that the core is fully inserted to the centre wall.
4. Fit the universal shear screws within the connector and torque tighten one turn at a time, using the correct tool, until the bolts have sheared.
5. De-burr and clean the connector as appropriate **ensuring the profile of the screws are level with the connector body and leaving no sharp edges.**

***IMPORTANT:** When using the USMF5 the centralising ring must be used on cable sizes #2 to 2/0 AWG, inclusive.