

**JTS Tools**

JTS/1 Cable Armour Bond Tensioning Tool

Length: 225mm Weight: 1024 gms

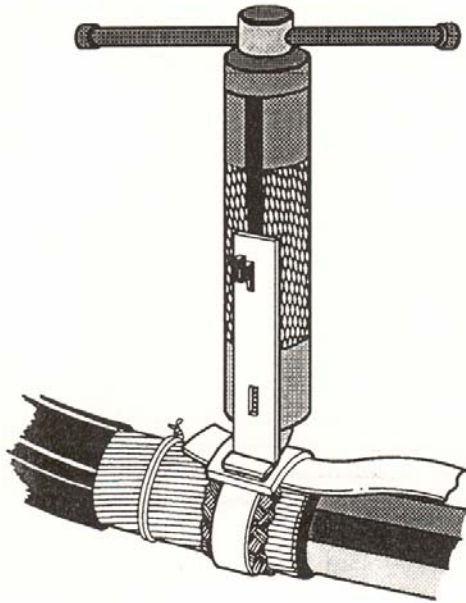

This tool is designed for use with the Hepworth Armour Bond system when the continuity bonds are to be secured with tension-straps (HBT tension-strap fixing). An efficient electrical contact between the cable armour and the continuity bonds is achieved by means of a mild steel strap which is tensioned around the armour, over an inserted copper braid bedding, with the aid of the tool. Illustrated details of this technique are included in Section 4 : Cable Armour Bonding Systems : Page 4.07.

JTS/2 Lightweight Tensioning Tool

Length: 121mm Weight: 175 gms

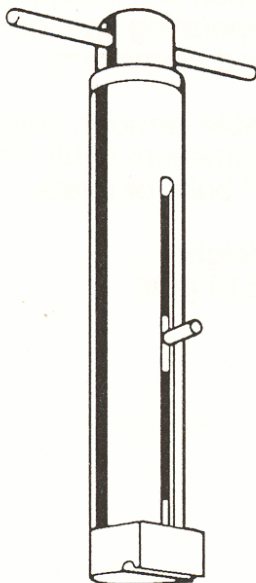

This device is designed for use with the Hepworth Consumers Earth Bond system. An efficient contact between the cable earth sheath and the consumers earth point is achieved by tensioning a copper strap around the sheath with the aid of the tool. Uniform contact around the earth sheath is achieved by inserting the copper braid earth link beneath the copper strap to act as a bedding. Excessive pressure cannot be applied as the copper tension strap is designed to tear away from the spigot on the tool when the correct tension is achieved. Illustrated details of this system are included in Section 8 : Miscellaneous Products; Consumer Earth Bonds : Page 8.05.

**JTS Tools****JTS/3 Range**

## Lifting Keys

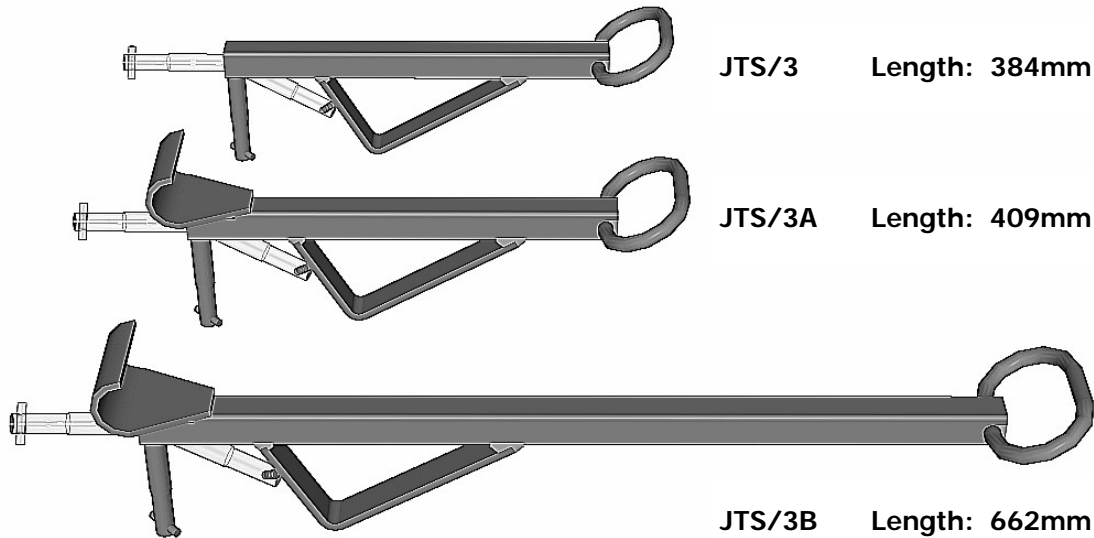

The Hepworth JTS/3 range of Lifting Keys has been designed to free road level inspection covers and assist in their lifting under adverse conditions such as the ingress of dirt or grit, rusting, frost and ice, or impact from heavy vehicles. The initial seal is broken by using the lifting key horizontally so that, by means of a simple contilever effect, the cover can be dislodged when pressure is applied to the lifting key handle. Once released, a position convenient for lifting the cover can be achieved by moving the key up to its vertical position, allowed for by the swivelling arm arrangement illustrated above. Alternatively, two people each with a key can lift awkwardly-placed or particularly heavy covers. The JTS/3A and 3B product has an additional feature of an integral hook for the lifting of Link Box bell covers.

Alternative types of lifting pins and hooks can be supplied to meet specific requirements.