

ME Connector Kit

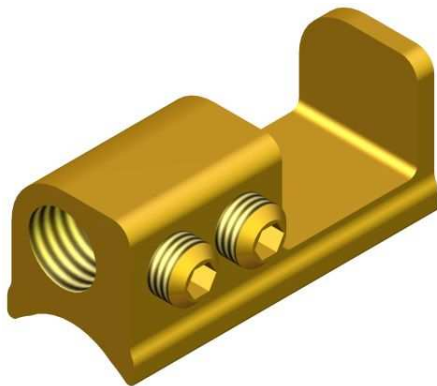

ME35



ME50, 120, 185 & 400

Principle Application:

Mechanical earth connection to BS 6480 LV 600/1000V impregnated paper insulated lead sheathed cable (PILC).

Range:

Connector Reference	Core c.s.a. (mm ²)			
	Service/Mains		Earth Bond	
	Min	Max	Min	Max
ME35	16	35	10	35
ME50	25	50	10*	70
ME120	25	120	10*	70
ME185	150	185	10*	70
ME400	150	400	10*	70

Note: For jointing other core configurations/sizes please contact Sicame Technical Dept

The **Hepworth ME** range of kits provide the end user with a quick and reliable connection onto the lead sheath of a range of PILC cables.

The profiled copper alloy 'saddle' sits firmly on the lead sheath, using knitted wire tape as the interface with the assembly held firmly in place using a stainless steel worm drive clip.

The end user can now position, cut to length and prepare the earth bond **BEFORE** the final torque controlled connection is made within the connector.

** When jointing 10mm² earth bond, 'double up' conductor core before inserting within the cable port.*

ME Connector Kit

Physical Dimensions

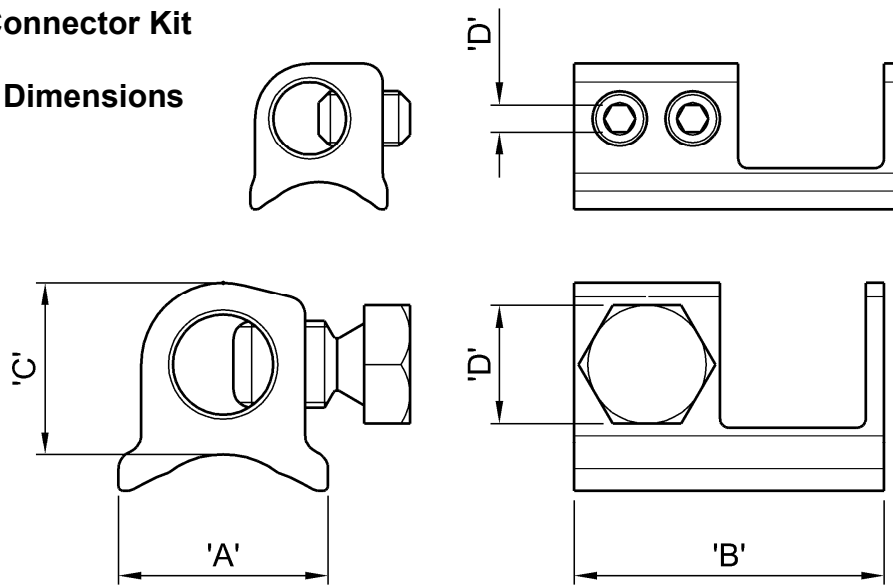

Kit Reference	Dimensions (mm)			
	A	B	C	D
ME35	15	36	12	2 x 3mm A/F grub screw
ME50	23	34	19	13 A/F
ME120	23	34	19	13 A/F
ME185	32	34	19	13 A/F
ME400	32	34	19	13 A/F

Material: Copper Alloy (Body/Screw)

Test Specification:

Designed to meet the requirements of Engineering Recommendation C93.

Test Report N°: TTR118, TTR189, TTR202, TTR209 and TTR219

Fitting Instructions:

1. Strip the mains/service cable to the required dimensions, as per individual REC jointing instructions.
2. Mark the lead sheath of the position where 'saddle' is to be located and abrade surface.
3. Wrap the knitted wire tape around the lead sheath and 'tie off'.
4. Position the saddle directly on the wire tape and secure in place using worm drive clip provided.
5. Apply vinyl mastic tape to create moisture seal as per individual REC jointing instructions.
6. Position the earth bond, cut to length and prepare the end for connection into the 'saddle' - abrade the copper wires.
7. Torque tighten the shear head screw until the head shears (ME35 do NOT shear).