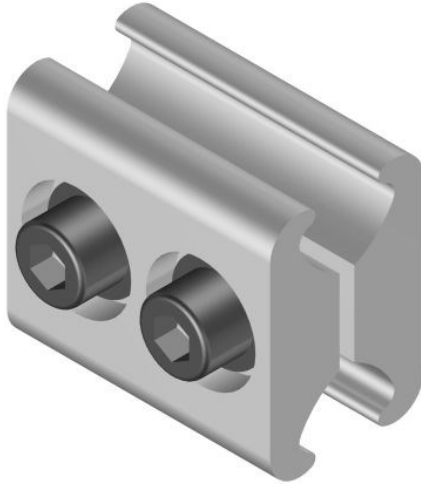
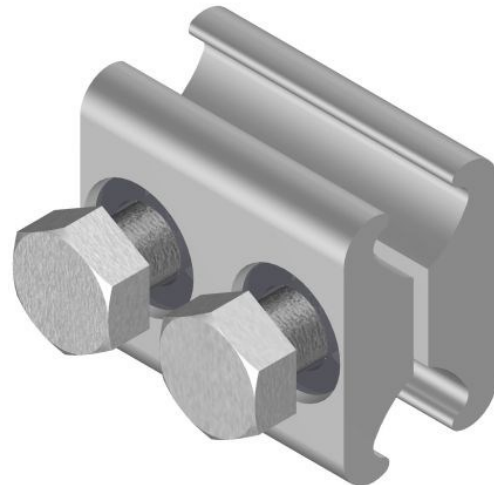

BST/A Connectors**BST/A(H) Connectors****Principle Application:**

Branch connections from solid sector shaped aluminium conductors.

Range:

Branch Conductor (mm ²)	Mains conductor (mm ²)						
	70	95	120	150	185	240	300
70	A1	A1	A1	-	-	-	-
95	-	A1	A1	A1	-	-	-
120	-	-	A1	A1	A1	-	-
150	-	-	-	ALL	ALL	-	-
185	-	-	-	-	A2 & A3	A2 & A3	A2 & A3
240	-	-	-	-	-	A2 & A3	A2 & A3
300	-	-	-	-	-	A2 & A3	A2 & A3

The **Sicame 'BST/A'** and '**BST/A(H)**' range of connectors have been designed to accommodate three or four core sector shaped solid aluminium conductors of similar sizes, within the ranges specified above. It should be noted, however, that these combinations are specified for the same sector shape, e.g. three core to three core. Should combinations of three and four core be required, it is suggested that verification of their suitability be obtained before use.

Each connector is supplied in a sealed polythene bag, and details of fitting procedures are included in the technical data overleaf.

NOTE: If required the **BST/A** connectors can also be supplied with 13mm A/F hexagon head set screws, **Product code BST/A1(H), BST/A2(H) & BST/A3(H)**.

BST/A Connectors

Physical Dimensions

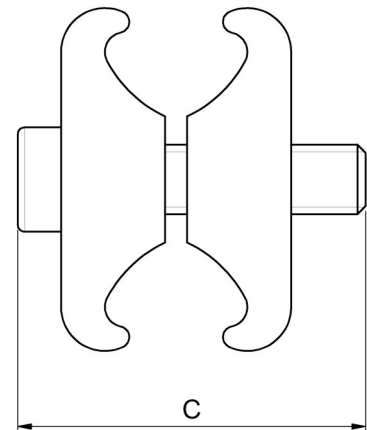
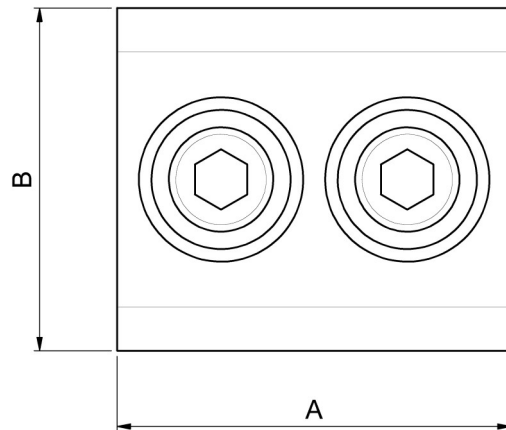

BST/A(H) Connectors

Physical Dimensions

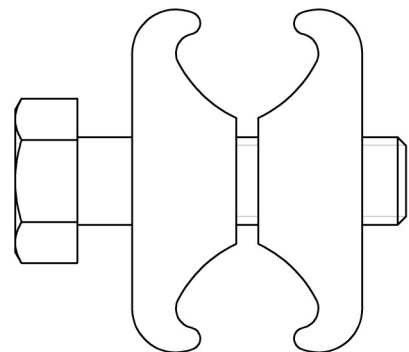
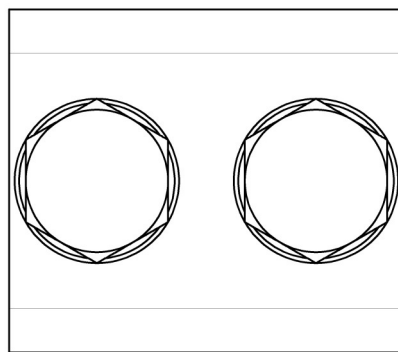

Connector Reference (Part Number)	Dimensions (mm)		
	A	B	C
BST/A1 (2466-186)	36	31.3	32
BST/A2 (2466-187)	36	31.3	38.5
BST/A3 (2466-188)	50	40.5	44

BSTA1(H) - 51807-39 BSTA2(H) - 51807-40 BSTA3(H) - 51807-45

Material: Aluminium Alloy

Fitting Instructions:

Strip the insulation from the mains core at the required position using the length of the connectors as a guide, and thoroughly abrade the exposed conductor. Set the branch conductor to achieve a curve-to-curve configuration and cut to length, then strip the insulation to match the main and abrade the exposed conductor. Loosely fit the connector, ensuring that the conductors are correctly aligned before fully tightening the socket head screws using a 3/16" A/F hexagonal drive.

***NOTE:** It may be found that with smaller conductor configurations the connector can accept the branch conductor with the apex facing inwards toward the main, but it is generally recommended that the conductors are set curve-to-curve to avoid any possible interference with the threads of the clamp screws. The **BST/A3** connector has been introduced to increase the range of application, and is suitable for all conductor orientations.