

UB1 Connector

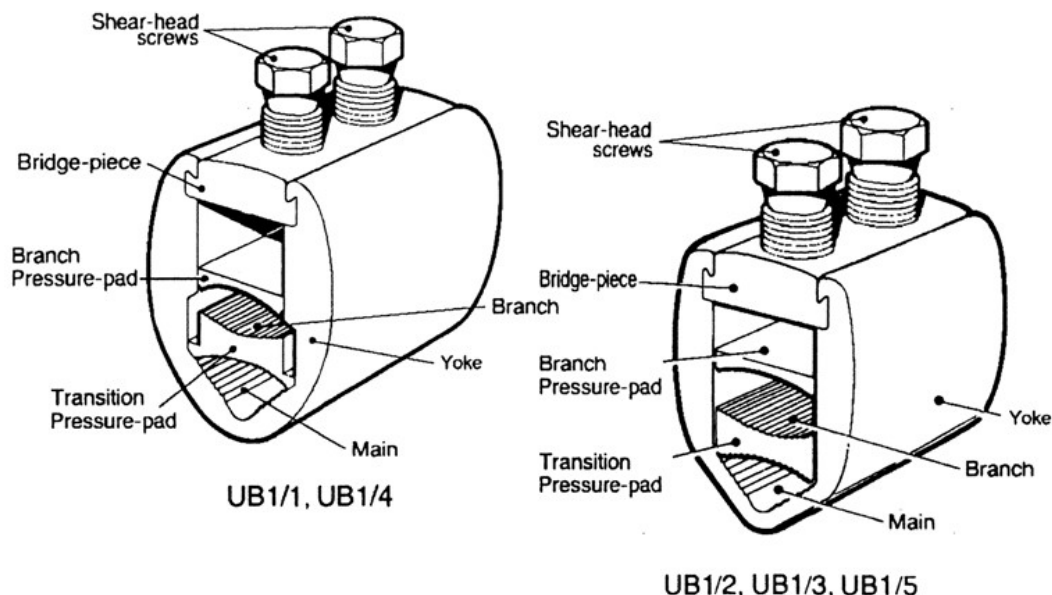

Principle Application

Stranded sector shaped conductors in the following ranges: -

Range

Connector Reference (Part Number)	Core c.s.a. (mm ²)				Approx Unit Wt. (gms)
	Mains		Branch		
	min.	max.	min.	max.	
UB1/1* (3395-535)	240	300	120	150	245
UB1/2+	240	300	185	300	310
UB1/3 (51807-53)	150	185	70	150	200
UB1/4	400	500	240	300	427
UB1/5	70	95	50	70	102

*NOTE: UB1/1N & UB1/2N available for circular neutral conductor

The Sicame UB range of connectors has been designed specifically for use with polymeric heat shrink insulation materials. When fully assembled the connector forms a smooth, contoured profile, free from projections and sharp edges, allowing the insulation to shrink evenly around the connection. The connector is simple to fit and the Sicame shear head screw system ensure that the correct clamping pressure is applied. A consistent connection is achieved without the use of specialised tooling.

The connector is supplied individually packed complete with fitting instructions details of which are included with the technical data overleaf. Brass gauze can be supplied on request for use with copper conductors.

UB1 Connector

Physical Dimensions

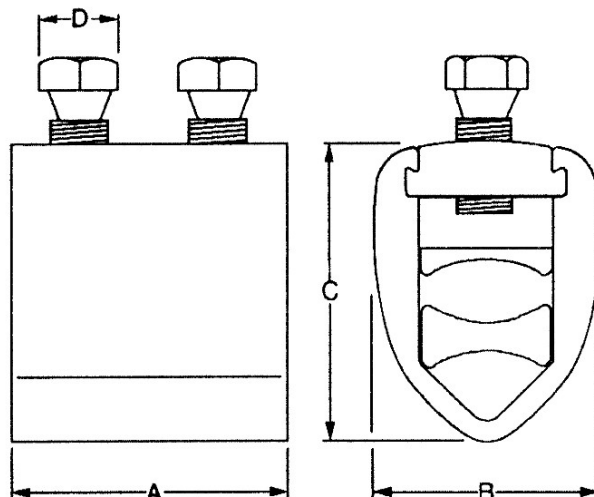

Ref. Code (Part Number)	Dimensions (mm)			
	A	B	C	D
UB1/1* (3395-535)	50.0	48.0	62.0	17.0
UB1/2	60.0	51.0	67.0	17.0
UB1/3 (51807-53)	50.0	39.0	55.5	17.0
UB1/4	60.0	61.2	76.0	17.0
UB1/5	40.0	28.0	42.0	13.0

Material

Aluminium Alloy

Fitting Instructions

Separate the main cable cores to enable the yoke of the connector to be fitted around the conductor. Strip the insulation equal to the length of the connector plus 5 mm from the core at the selected connection position. Set the branch core and cut to the required length. Strip the insulation as above. Thoroughly abrade all exposed conductors. Pass the connector yoke around the mains conductor and insert the transition pressure pad. Locate the branch core in the yoke and insert the pressure pad and bridge piece. Ensure the assembly is correctly aligned and hold firmly. Complete the operation by tightening the screws a quarter of a turn at a time until both heads shear off.

If copper conductors are to be jointed they should be wrapped in brass gauze before insertion into the yoke to improve electrical stability of the aluminium/copper interface in the connection.