

Mains service connectors double service

MECHANICAL CONNECTORS

UMS95/2S, UMS185/2S & UMS300/2S Connectors

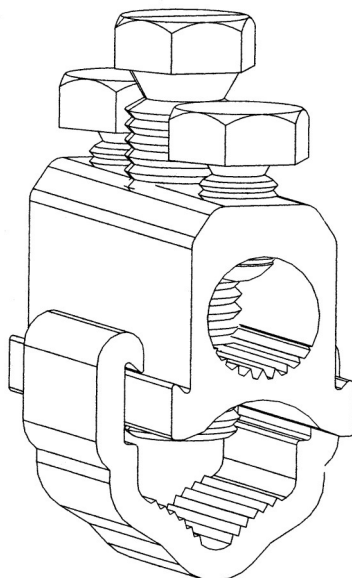

Principle Application

For LV mains service jointing of sector/round, stranded/solid, aluminium/copper conductor cores.

Range

Connector Ref (Part Number)	Mains mm ² (In ²)		Service (mm ²)		Approx Unit Weight (gms)
	Min	Max	Min	Max	
UMS95/2S (51801-18)	25 (0.04)	95 (0.15)	2 x 10*	2 x 70	82
UMS185/2S	35 (0.06)	185 (0.3)	2 x 10*	2 x 70	140
UMS300/2S	95 (0.15)	300 (0.5)	2 x 10*	2 x 70	188

Note: For jointing other core configurations/sizes please contact Sicame Engineering Department.

The **Sicame UMS95/2S** range of mains service connectors accommodates an extensive range of LV mains cable style and sizes.

The connector utilises the proven shear head, direct acting bolts (plated) thereby removing the need for pressure plates.

The plated bolts, combined with a standard plated yoke section, allow for the jointing of mains copper conductor cores without the need for conventional brass gauze.

**Mains service connectors
double service**

**MECHANICAL
CONNECTORS**

**UMS95/2S, UMS185/2S & UMS300/2S
Connectors**

Physical Dimensions

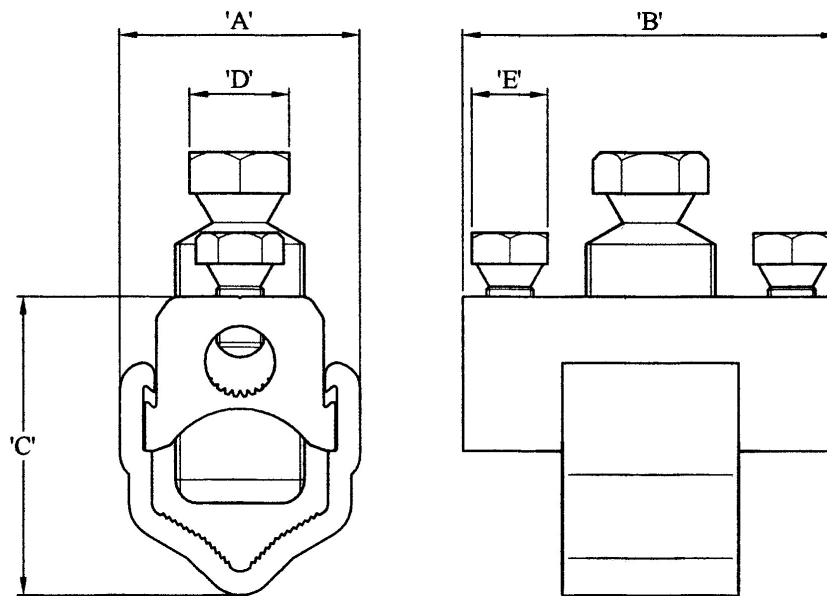

Connector Ref (Part Number)	Dimensions (mm)				
	A	B	C	D	E
UMS95/2S (51801-18)	26.0	58.0	36.5	13 A/F	13 A/F
UMS185/2S	35.0	64.0	44.5	17 A/F	13 A/F
UMS300/2S	41.0	68.0	51.0	17 A/F	13 A/F

Material

Aluminium Alloy

Copper Alloy (Service Shear Screw)

Test Specification

Designed to meet the requirements of Engineering Recommendation C79 and IEC 1238-1.

Stranded service conductor less than 10mm² should be doubled and re-doubled, where necessary, to achieve a satisfactory cross section area.