

Mains service connectors—
double service

MECHANICAL CONNECTORS

UMS185D/2S & UMS300D/2S Connectors

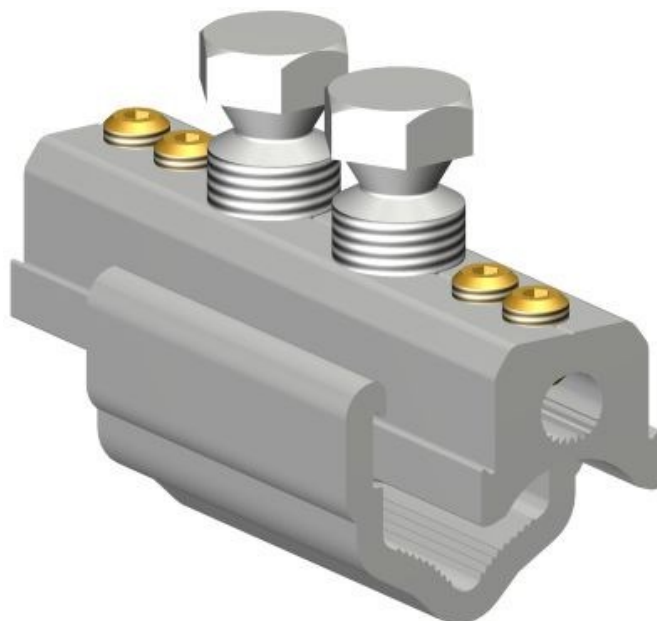

Principle Application

For LV mains jointing of sector/round, stranded/solid, aluminium/copper conductor cores.

Range

Connector Reference	Mains (mm ²)		Service (mm ²)	
	Min	Max	Min	Max
UMS185D/2S	50	185	10	2 x 35
UMS300D/2S	95	300	10	2 x 35

Note: For jointing other core configurations/sizes please contact Sicame Engineering Dept

The **Sicame UMSxxxD/2S** range of mains service connectors accommodates an extensive range of LV cable styles and sizes.

The connector incorporates proven shear head technology whilst utilising direct acting bolts (plated) thereby removing the need for pressure plates.

The plated bolts combine with a standard plated yoke section to allow for the jointing of mains copper conductor cores without the need for the conventional brass gauze.

Mains service connectors—
double service

MECHANICAL CONNECTORS

UMS185D/2S & UMS300D/2S Connectors

Physical Dimensions

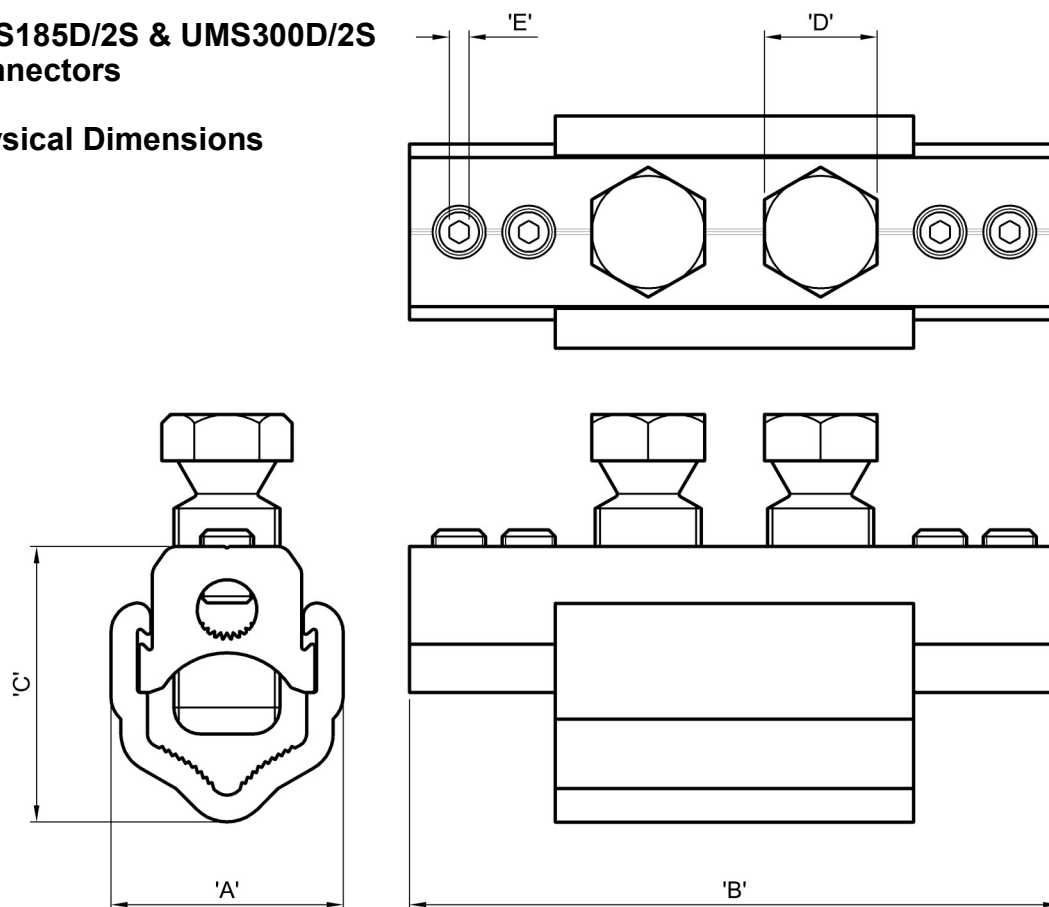

Connector Reference	Dimensions (mm)				
	'A'	'B'	'C'	'D'	'E'
UMS185D/2S	35.0	98.0	41.5	17 A/F	3 A/F
UMS300D/2S	41.0	108.0	47.7	17 A/F	3 A/F

Material

Aluminium Alloy

Brass (Service Grub Screws)

Test Specification

Designed to meet the requirements of IEC1238-1, BS EN 61238-1:2003.